

# D88 Drone

## User Manual

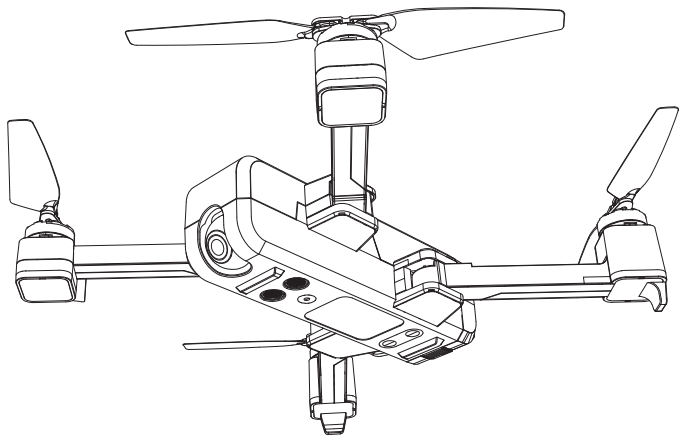

**Potensic**<sup>®</sup>

**2K 5G**  
2048 x 1152 Farther.Faster.Clearer

# Contents

## Product Overview

Introduction	1
Prepare Your D88 Drone	1
Prepare the Remote Controller	2
Major Parts & Functional Switch	3

## Aircraft

Flight Modes	5
Aircraft Status Indicator Lights	6
Return to Home (RTH)	7
Vision System	9
Aircraft Power Switch	11
Aircraft Battery	11
Attach and Detach the Propellers	13

## Remote Controller

Remote Controller Functions and Status	14
Throttle Control Stick Mode	19
Install Mobile Phone Holder	20

## App Download & Installation

FPV Real-time Image Transmission App "Potensic-M2"	21
--	----

## Flight

Flight Environment Requirements	23
Pre-flight Checklist	23
Aircraft Operations	24
Test Flight	28

## Appendix

Product Parameters	29
Packing Detail	32
Important Statement	33
Flight Safety Guidelines	33

## Product Overview

This section mainly introduces functions and installation guidelines of D88 and lists the components of the aircraft and remote controller.

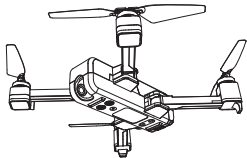

## Introduction

- Equipped with Optical Flow Positioning and GPS System, your D88 can precisely position, hover and automatically return. It is also capable of flying in the intelligent flight modes such as Point of Interest, Follow Me and Waypoint Flight. Features a single-axis gimbal, your D88 can shoot 2K photos and adjust camera angle 90 degrees in flight.
- The aircraft and camera can easily be controlled using the onboard buttons. Real-time images and aircraft data information can be shown on the "Potensic-M2" APP. Foldable hand sticks and pull-out holder design make the remote controller easier to operate and carry.
- Maximum flight speed is 40km/h and maximum flight time is 22 minutes.

## Prepare Your D88

### Unfold the aircraft

The Aircraft is folded inside the package. Follow the steps as below to unfold the aircraft.

Step 1: Unfold the rear arms (Pic. 1);

Step 2: Repeat again to unfold front arms (Pic. 2).

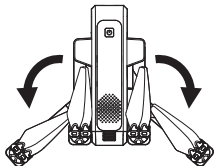

Pic. 1

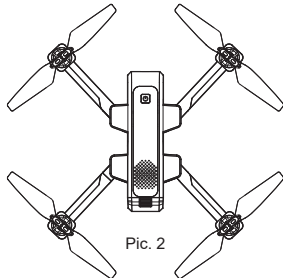

Pic. 2

### Battery installation

Slide the battery into the battery compartment at the rear of the aircraft by pushing with appropriate force. Make sure that you hear a click sound indicating the battery is firmly installed.

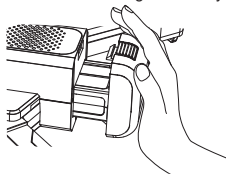

Attention: The battery should be installed firmly, failure to do so may affect the flight safety of your aircraft. The aircraft may crash due to power-disconnecting during the flight.

## Prepare the Remote Controller

### Install the battery of remote controller

Step 1: Unfold the hand sticks and open the battery cover (Pic. 1);

Step 2: Install two\*AA batteries into the battery compartment according to the given polarity (Pic. 2);

Step 3: Close the battery compartment (Pic. 3).

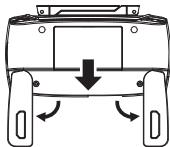

Pic. 1

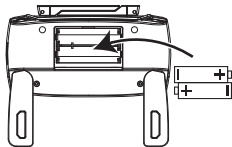

Pic. 2

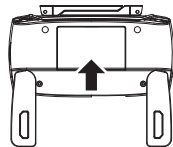

Pic. 3



- Insert batteries with correct polarity.
- Do not mix up the old batteries with the new ones.
- Do not mix alkaline, standard (carbon-zinc), or rechargeable (nickel-cadmium) batteries.
- Ensure the rechargeable batteries have been removed from the aircraft before being charged.
- Rechargeable batteries are only to be charged under adult supervision.
- Exhausted batteries must be removed from the aircraft.

## Major Parts & Functional Switch

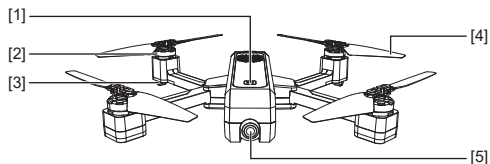

- [1] Power switch
- [2] Brushless motor
- [3] Undercarriage
- [4] Propeller
- [5] Camera

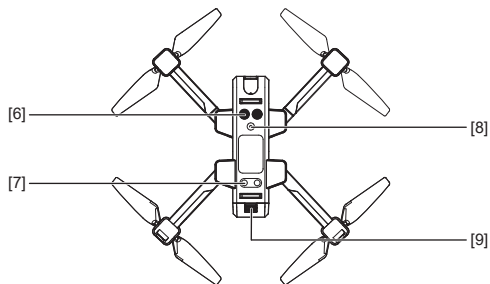

- [6] Ultrasonic sensor
- [7] Bottom lights
- [8] Optical flow positioning camera
- [9] Battery

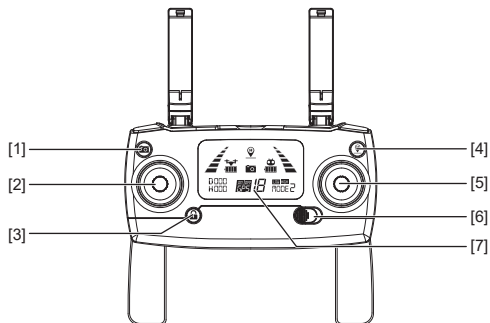

- [1] Photo/Video
- [2] Throttle stick
- [3] One-key unlock/lock
- [4] One-key RTH
- [5] Direction stick
- [6] Power switch
- [7] LCD display

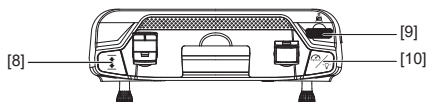

[8] One-key taking off one-key landing

[9] Gimbal trimmer

[10] Light switch (short-press);  
High/Low speed switch  
(long-press)

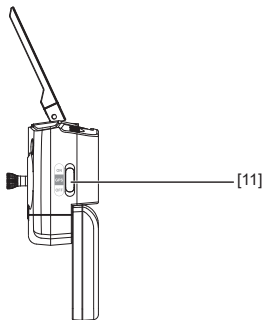

[11] GPS/Gesture  
mode switch

## Aircraft

This section introduces functions and features of the D88.

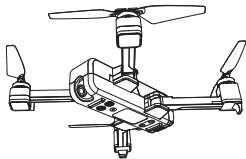

### Flight Modes

Your D88 has 3 flights modes:

#### GPS mode: ON

Turn on the GPS mode (Pic.1), the aircraft can precisely position and hover by the assistance of the GPS module.

(Warm Tips: When the GPS signal is weak, the aircraft will automatically enter into Gesture mode (flying altitude  $\geq 3$  meters) or optical flow positioning mode (flying altitude  $< 3$  meters).

#### Gesture mode: OFF

Turn off the GPS mode, then the aircraft enter into Gesture mode. The positioning system will be shut down, and functions under GPS mode can not work. The drone can not accurate hover at a fixed point, so please land your drone in a safe place in time if you can not control it well. (You should be aware that weak GPS signal may cause your drone out of control)

#### Optical flow positioning:

Once the GPS signal is weak or unavailable and the flying altitude is less than 3 meters, the aircraft will automatically enter into optical flow positioning. Assisted by this function, the aircraft could perform precisely positioning.

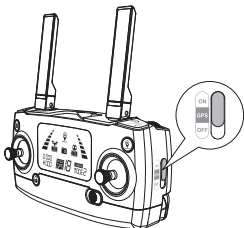

Pic. 1

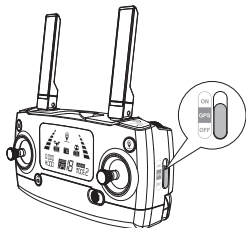

Pic. 2

## Aircraft Status Indicator Lights

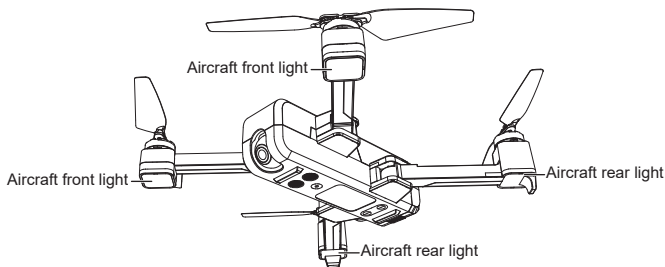

### Aircraft status indicator



No.	Indicator status	Meanings
1	Front and rear lights flash yellow rapidly.	Aircraft 2.4GHz disconnected.
2	Front and rear lights flash red, green and yellow alternatively.	Aircraft is in initialization detection status.
3	Front lights glow solid red, rear lights glow solid green.	No GPS signal, aircraft is in gesture mode.
4	Front light glows solid red, rear light glows solid green.	Good GPS signal, aircraft is preparing for GPS mode.
5	Front and rear lights flash green rapidly.	Aircraft is in gyroscope calibration status.
6	Front and rear lights flash yellow alternatively.	Aircraft is in compass horizontal calibration.
7	Front and rear lights flash green alternatively.	Aircraft is in compass vertical calibration.
8	Front light glows solid red, rear light flashes red slowly.	Aircraft is nearly low voltage, 1/6 battery level left.
9	Front light glows solid red, rear light flashes red rapidly.	Aircraft is in low voltage, only 1/8 voltage left.



No.	Indicator status	Meanings
10	Front and rear lights flash red rapidly.	Something wrong with ultrasonic altitude hold data and the aircraft is in barometer altitude hold.
11	Front and rear lights flash once, stop for 1.5 second.	Something wrong with the gyroscope.
12	Front and rear lights flash twice, stop for 1.5 second.	Something wrong with the barometer.
13	Front and rear lights flash three times, stop for 1.5 second.	Something wrong with the compass.
14	Front and rear lights flash four times, stop for 1.5 second.	Something wrong with the GPS module.
15	Front and rear lights flash five times, stop for 1.5 second.	Something wrong with the ultrasonic module.
16	Front and rear lights flash six times, stop for 1.5 second.	Something wrong with the optical flow positioning

## Return to Home (RTH)

The Return-to-Home (RTH) function brings the aircraft back to the last recorded Home Point. There are 3 types of RTH: smart RTH, low battery RTH and failsafe RTH. This section describes these 3 scenarios in detail.

	GPS	Description
Home Point		If a strong GPS signal (satellites over 7) was acquired before taking-off, the Home Point is the location from which the aircraft launched. The GPS signal strength is indicated by the GPS icon (  ). The aircraft rear indicator lights will blink rapidly from yellow color to green color when the home point is recorded.



- Aircraft can not avoid obstacles when it is flying back with the RTH function initiated.
- Aircraft can not return to the Home Point when the GPS signal is weak or unavailable.
- Aircraft will stop ascending and immediately return to the Home Point if user moves the throttle stick in the aircraft reaches 15 meters altitudes or beyond during Smart RTH.
- If there is no GPS signal and the remote controller signal lost for more than 6 seconds, the aircraft can not Return-to-Home but descend slowly until land to the ground and lock the aircraft.

## Smart RTH

When the GPS signal is available (more than 7 satellites is presented), use the RTH button  on the remote controller (Pic. 1) or tap the RTH button on the App (Pic. 2) and then follow the on-screen instructions to initiate Smart RTH. During the smart RTH, you can operate the joystick to control your drone to avoid obstacle. You can press the RTH button again to exit RTH procedure and regain control of the aircraft.

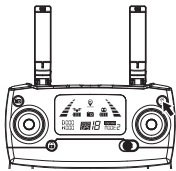

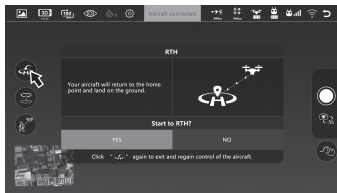

Pic. 1



Pic. 2

## Low Battery RTH

1. When the aircraft rear lights flash slowly, battery icon  is shown on the remote controller or on the APP. And steady "beep beep beep... beep beep beep" sound is heard. At this moment, the aircraft will automatically return to the Home Point if the flying altitude is beyond 50 meters or the flying distance against the home point is beyond 100 meters.
2. When the aircraft rear lights flash slowly, battery icon  is shown on the remote controller or on the APP. And steady "beep..beep...beep" sound is heard. At this moment, the aircraft will automatically return to the Home Point if the flying altitude is beyond 15 meters or the flying distance against the home point is beyond 15 meters. If the distance is within 15m, the drone will land on the ground.



**Attention:** When the aircraft is automatically return home with Low Battery RTH function will be activated, you can not cancel the RTH procedure by pressing the RTH button to regain control of the aircraft.

## Failsafe RTH

If the Home Point was successfully recorded and the compass is functioning normally, Failsafe RTH will be automatically activated if the remote controller signal is lost beyond 6 seconds. Return-to-Home can be cancelled by the pilot, allowing them to regain control when the remote controller signal connection is reconnected during the returning.

## Optical Flow Positioning

Consisted by camera ① and ultrasonic sensor ②, the Optical Flow Positioning locates at front bottom of your D88. It is a positioning system that is composed by image sensor and ultrasonic sensor. Your D88 acquires its location through using the camera sensor to detect the ground texture and visible features.

Meanwhile, assisted by the ultrasonic sensor, your drone could determine the altitude where it stays, which could better insure the fly safety and gain precisely positioning.

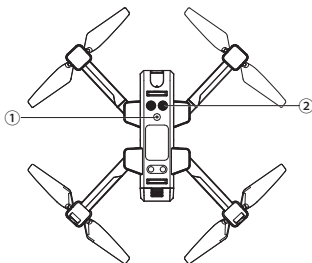

## Optical Flow Positioning

The Vision Positioning System is typically used in indoor environment when GPS is weak or unavailable. It works best when the aircraft altitude is less than 3 meters.

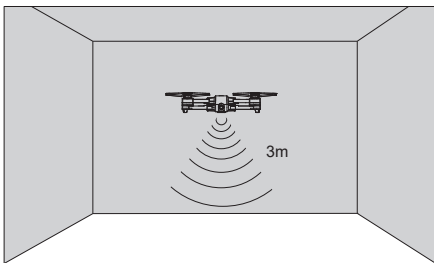

 The precision of the optical flow positioning system is easily affected by the light strength and features of the surface textures. It would happen that the ultrasonic sensor could work normally to detect the altitude when it is flying over objects that is made by sound-absorbing materials. Once the image sensor and ultrasonic sensor are both not available, your aircraft will switch to Gesture mode automatically. Be cautious to operate the aircraft in the following situation:

1. Fly fast at an altitude below 0.5m.
2. Fly over monochrome surfaces (like pure black, pure red, pure red and pure green).
3. Fly over strong light reflective surfaces or surfaces prone to reflection.
4. Fly over water or transparent object surfaces.
5. Fly over moving object surfaces (such as crowds, swaying juggles and glass).
6. Fly over an area where light changes dramatically and rapidly.
7. Fly over surfaces extremely dark ( $lux < 10$ ) or extremely bright ( $lux > 10,000$ ).
8. Fly over material surfaces that is good at absorbing ultrasonic waves (like thick carpet).
9. Fly over surfaces without clear textures.
10. Fly over surfaces with highly repeating textures (small grid brick in the same color).
11. Fly over surfaces that are tilting over 30 degrees (could not receive the echo of the ultrasonic wave).
12. Flying speed should be controlled not to be too fast. When the aircraft is 1 meter against the ground, the flying speed should not be over 5m/s; When the aircraft is 2 meter against the ground, the flying speed should not be over 14m/s.

- 
- Keep sensors clean at all times.
  - The optical flow positioning system is only effective when the aircraft is within the altitude range of 3 meters.
  - Make sure that the light is bright enough and the surfaces is with clear textures so that the vision system can acquire the movement information through recognizing the ground textures.
  - The vision system may not function properly when the aircraft is flying over water, low light ground and surfaces without clear patterns or textures.
  - Do not use other ultrasonic device with a frequency of 40KHz when the vision system is in operation.

---

 Attention: Keep animals away from the aircraft when the vision system is activated. The ultrasonic sensor emits high frequency sounds that are audible to some animals.

---

## Aircraft Power Switch

### Turn on the aircraft

Once battery is installed firmly, press on the power switch for 3 seconds, the aircraft makes beep sounds and the lights keep flashing.

### Turn off the aircraft

Press on the power switch for 3 seconds, the aircraft lights go off and the D88 turns off.

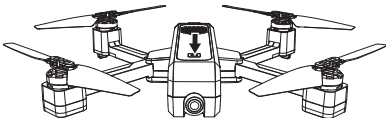

## Aircraft Battery

- Made by high quality battery cells;
- Standard battery capacity is 7.6V 3400mAh.

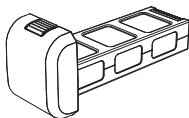

Aircraft battery

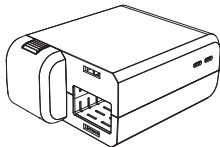

Charger

### Charge the aircraft battery

- The aircraft's battery needs to be fully charged before every flight;
  - Please use USB charging device for this aircraft;
  - Full charging time for one battery is about 4 hours.
- 1) One charging cable is capable of charging one battery at one time;
  - 2) Two batteries charging at the same time takes 8 hours to fully charge.

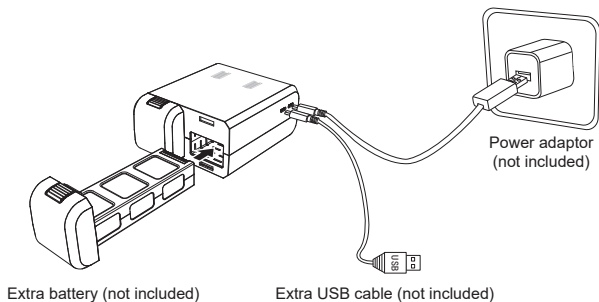

Adult supervision is necessary when children are playing.

- Only batteries of the same or equivalent type as recommended are to be used.
- Insert batteries with correct polarity.
- Rechargeable batteries are to be removed from the aircraft before being charged.
- Rechargeable batteries are only to be charged under adult supervision.
- Exhausted batteries are to be removed from the aircraft.
- The supply terminals are not to be short-circuited.
- Regularly examined the cable line for potential hazard, such as damage to the cable or cord, plug, enclosure of other parts and that in the event of such damage, the product must not be used until properly removing the damages.

## Attach and Detach the Propellers

### Attach the propellers

Install propeller A and propeller B on the corresponding motor shaft and fix the rotor propellers tightly by rotating clockwise. (A / B mark are at the bottom of the propeller.)

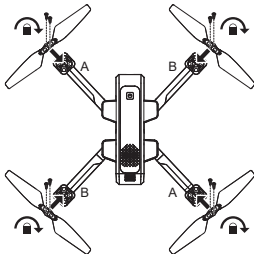

### Detach the propellers

Take out the screws by rotating counter-clockwise and then remove the propellers.

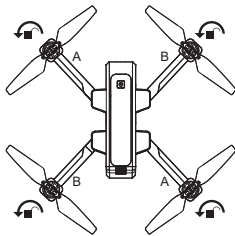

- Please make sure that the clockwise and the counter-clockwise propellers are installed on the correct motors, because the aircraft will not fly normally for wrong propellers installation.
- Be aware of the sharp edges of the propellers. Handle with care.
- Use only the Potensic D88 approved propellers. **DO NOT** mix propeller types.
- Stand clear of the motors and **DO NOT** touch the propellers when they are spinning.
- Check that the propellers and motors are installed correctly and firmly before every flight.
- Ensure that all propellers are in good condition before each flight. **DO NOT** use aged, chipped, or broken propellers.
- To avoid injury, **STAND CLEAR** of and **DO NOT** touch propellers or motors when they are spinning.
- **ONLY** use original Potensic D88 propellers for a better and safer flight experience.

## Remote Controller

This section describes the features of the remote controller, including the instruction on controlling the D88.

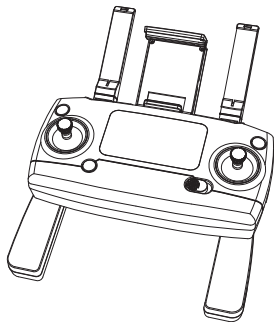

## Remote Controller Functions and Status

### Flight mode switch

Choose the flight mode by switching the GPS button to ON / OFF position. The on-working flight mode "GPS" is shown on the LCD display.

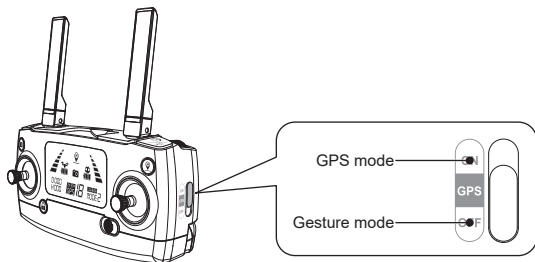





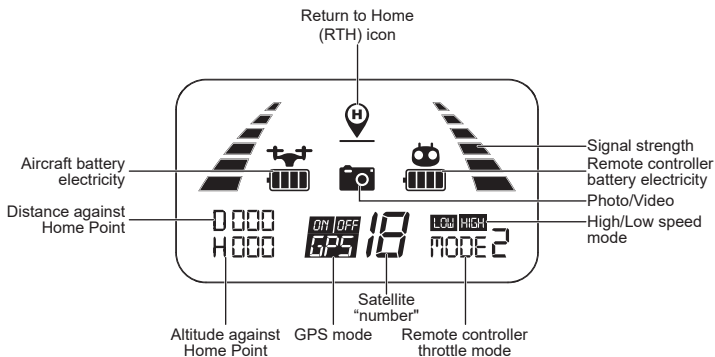

## LCD screen display



## Aircraft status indicator

No.	Remote controller status	Description
1	Signal strength indicator changes circularly from weak to strong.	The remote controller is under signal connection status.
2	Indicator lights flash slowly with steady "di di... di di..." sound and the battery "icon"  on LCD display flashes.	The remote controller is in low voltage. Please change a full charged battery.
3	Battery icon shows  on LCD display, with steady "di di di... di di di..." sound.	Battery is running out  ; the aircraft will return when the altitude is over 50m or the distance is over 100m.
4	Battery icon shows  on LCD display, with steady and long "di" sound.	Battery is low  ; the aircraft will return when the altitude is over 15m or the distance is over 15m; if either the flying altitude or flying distance is less than 15m, the aircraft will land to the ground.
5	Signal strength on LCD display is less than two grids or no displaying, with steady long beep sound.	<ol style="list-style-type: none"> <li>The distance between aircraft and remote controller is so long that the signal is weak.</li> <li>The battery is removed after the aircraft connects to the remote controller.</li> </ol>

### Gimbal trimmer

The camera angle can be adjusted within a 90 degree range by operating the gimbal trimmer. The controlling directions shows on the following pictures.

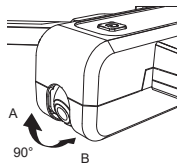
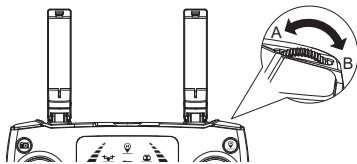

The camera can be rotated by 90 degrees.

### Photo/Video

Short-press the button indicated as below, the camera icon "📷" on the LCD screen flashes once, the camera takes one photo;

Long-press the same button, the video icon "📹" on the LCD screen flashes slowly, the camera is taking video. Long-press again will exit shooting.

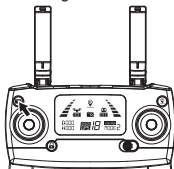

Attention: When the aircraft is not inserted with TF card or the TF card is malfunction, photos and videos taking can not be done .

### One-key takeoff/landing

- After the D88 unlocked, short-press the "⬆️" button (indicated as below), the aircraft will automatically take off and hover at 1.5m altitude.
- When the aircraft is flying, short-press the "⬆️" button (indicated as below), the aircraft will automatically land on the ground.

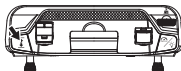

### Emergency stop

Press the “” button for 3 seconds to stop the flight urgently **ONLY** when the aircraft encounters emergency, or the aircraft will drop down or be crashed.

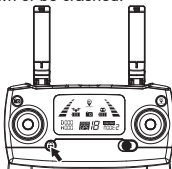

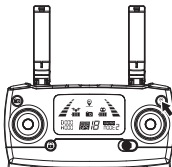

### Smart RTH button

- Press the button  to start the RTH, the remote controller makes a beep sound and the aircraft will fly back to the recorded Home Point.
- Press the RTH button again to exit RTH procedure and regain control of the aircraft.
- For more information about RTH, please turn to Return to Home section.



### Low battery warning

- When the battery icon “” is shown on the LCD screen (Pic. 1) with steady “beep beep beep... beep beep beep” sound, it means that the aircraft battery is nearly low voltage. At this time, the aircraft front lights glow solid on and rear lights flash slowly. **The aircraft will perform smart RTH when the altitude is over 50m or the distance is over 100m.**
- When the battery icon “” is shown on the LCD screen (Pic. 2) with steady “beep ...beep” sound, it means that the aircraft battery is in low voltage. At this time, the aircraft front lights glow solid on and rear lights flash rapidly. **The aircraft will return when the altitude is over 15m or the distance is over 15m; if either the flying altitude or flying distance is less than 15m, the aircraft will land to the ground.**

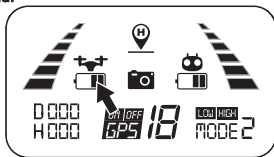

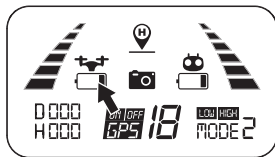

Pic. 1



Pic. 2

### Signal strength indicator

- This “” displays the signal strength, more number of black grids means more strong signal.
- When the strength bar “” changes from weak to strong circularly, it means that the remote controller is under signal connection status.
- There are 2 situations that the strength bar “” is less than 2 grids or no displaying with steady long beep sounds.
  - 1) The distance between the aircraft and the remote controller is too far causing a weak signal.
  - 2) The battery is removed after the aircraft connects to the remote controller.

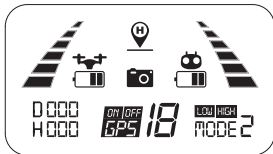

### Optimal transmission zone

To obtain a satisfied flight experience, please make sure that your D88 is flying ahead of the remote controller and no obstacles between the aircraft and the remote controller.

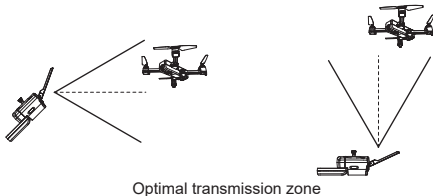

## Throttle Control Stick Mode

### Throttle mode switch

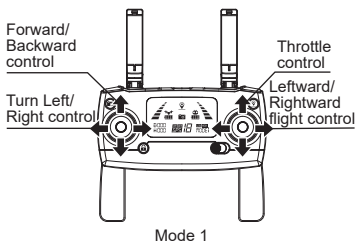

Mode 1

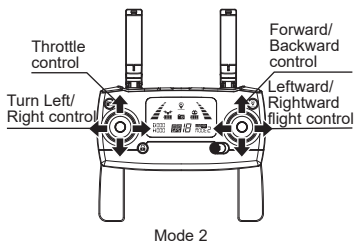

Mode 2

Mode 1: The right stick serves as the throttle.

Mode 2: The left stick serves as the throttle.

- The remote controller is set at Mode 2 by default.

### How to change throttle mode

Step 1. Keep pressing the red button "🔒" and turn on the remote controller, the remote controller is under signal connection status (Pic. 1);

Step 2. Keep pressing the RTH button "🏠" for 3 seconds to choose the throttle control mode (Pic. 2).

The throttle control mode will change according to each press. The mode number is shown on the LCD screen. The throttle control mode is set at mode 2 by default.

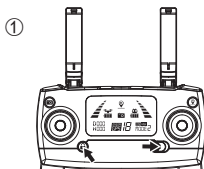

Pic. 1

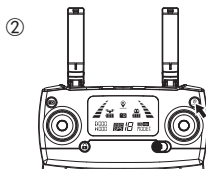

Pic. 2



**Attention:** To change the stick mode of the remote controller, please make sure that the remote controller is under signal connection status (the indicator light keep flashing). Otherwise, the stick mode could not be changed.

## Install the Mobile Phone Holder

1. Pull out the mobile phone holder upwards completely (Pic. 1);
2. Tilt the holder 30 degrees towards you and then you will hear a click sound (Pic. 2);
3. Rotate and fix the support board in place (Pic. 3);
4. Adjust the mobile phone holder upward or downward according to the size of your mobile phone (Pic. 4).

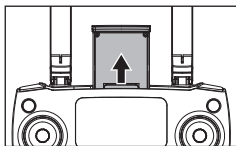

Pic. 1

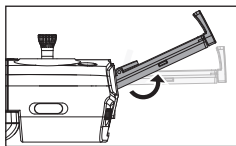

Pic. 2

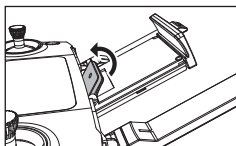

Pic. 3

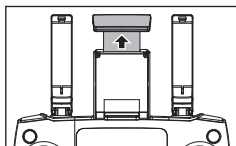

Pic. 4

## App Download & Installation

---

This section introduces how to download the "Potensic-M2" APP and connect with mobile device.

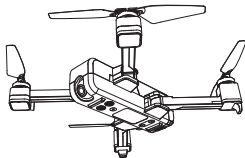

## FPV Real-time Image Transmission Software "Potensic-M2"

### Where to download "Potensic-M2" APP

1. For Apple IOS system, please turn to Apple store, search "Potensic-M2" or scan the QR code as below to download the software.
2. For Android system, please scan the "Google play" or drone's QR code or search "Potensic-M2" in "Google play" to download the software.



### How to link the "Potensic-M2" to the camera

Power on the aircraft, then enter phone setting option. Turn on WiFi, find "drone \*\*\*" on the list and connect it. When "WiFi" legend is shown, it means WiFi connection is successful. Exit settings and tap "Potensic-M2" APP at your mobile device, then select your aircraft model on the home page; click "GO" to enter into the real-time image transmission interface.

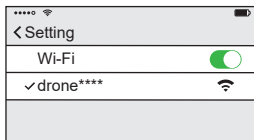

Connect WIFI



Potensic-M2

Tap "Potensic-M2" App

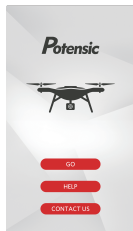

Click "GO"

### Photos and video saving feature

1. If the camera is without TF card, videos and photos will be saved at the APP.
2. If the camera is with TF card, videos and photos will be saved at the TF card.
3. Videos and photos in the TF card can be downloaded to the APP.



Attention: Please make sure that your mobile device supports 5G WIFI before linking "Potensic-M2" to your device.



Real-time image quality and FPV distance depend on your smart phone and flight environment. To obtain the best live view, please choose a wide open area to fly in. As tested, the drone could transmit 2K videos up to 800 meters (0.6 mile) in an environment with no interference.



## Flight

---

This section introduces safe flight requirements and basic aircraft operations.

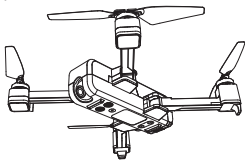

## Flight Environment Requirements

1. Please don't fly in such bad weather conditions as high temperature, snow, strong wind ( $\geq$ level 5), rain or fog.
2. Always choose a wide open area for every flight. Tall structures and large metal structures may affect the accuracy of the onboard compass and GPS system.
3. Well away from people and property. Never fly directly over people or animals.
4. To minimize interference, please do not fly the aircraft in locations near power lines, base stations, electrical substations and broadcasting towers.
5. Aircraft and battery performance is subject to environment factors like temperature. Be very careful when flying over 6KM above sea level since the performance will be affected.
6. Your D88 cannot use GPS within the polar regions.

## Flight limits and GEO zones

Abide by all laws and regulations when flying your D88. Flight limitations are applied by default to help users operate this product safely and legally. Flight limitations include altitude limits, distance limits and GEO Zones.



Altitude limits, distance limits and GEO Zones function concurrently to manage flight safety when operating in GPS Mode.

## Pre-flight Checklist

1. The aircraft, remote controller and mobile device are full charged;
2. The propellers are installed correctly;
3. The arms and propellers are unfolded;
4. Ensure the camera lens are clean;
5. Please use the drone parts that are certified by Potensic D88. Otherwise, it may cause malfunction or safety issues.

## Aircraft Operations

### Signal connection between the aircraft and remote controller

- Keep pressing the red button “” and turn on the remote controller (Pic. 1). The remote controller makes 2 beep sounds, and the indicator light “” keeps flashing; the remote controller is under signal connection status.
- Turn on the aircraft (Pic. 2). The aircraft will make beep sounds with front and rear lights flashing and will automatically link to the remote controller. Once the remote controller sends out a long beep sound and the indicator light of the remote controller turns from flashing to solid on and the signal icon “” is shown on the LCD screen, it means that the signal is connected successfully.



Pic. 1

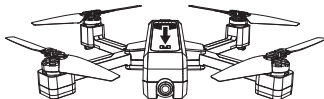

Pic. 2



- Signal connection is done once for all if the remote controller is not linked to other aircraft.
- Set the connection one by one to avoid signal connection error.

### Aircraft initialization detection

After signal connection, the aircraft enters into initialization detection procedure with front and rear lights flashing red, green and yellow alternatively. Make sure that the aircraft is set on a flat and still surface for the initialization detection. The aircraft initialization detection takes about 8 seconds. Once the remote controller sends out “Di Di” sounds and the aircraft front and rear lights flash yellow alternatively, initialization detection is completed.

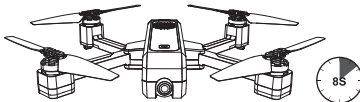

Attention: Make sure that the aircraft is set on a flat and still surface for the initialization detection.

## Aircraft compass calibration

1. Compass calibration should be performed after successful aircraft initialization detection.
2. Aircraft compass calibration should be done for every flight. That is to say, if changing new battery or the battery is reinstalled, compass calibration should be done again.

Two steps of compass calibration:

### Step 1: Horizontal calibration

After successful aircraft initialization detection, the aircraft front and rear lights flash yellow alternatively. Hold the aircraft horizontally and rotate it 360 degrees along the central axis for about 3 circles. The aircraft front and rear light will change from flashing yellow alternatively to flashing green alternatively when horizontal calibration is completed.



### Step 2: Vertical calibration

Hold the aircraft with camera facing up, and rotate it 360 degrees along the central axis for about 3 circles until the front and rear lights of the aircraft change from flashing to solid on, the compass calibration is successful.

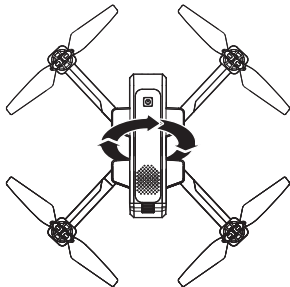

Attention: To fly at GPS mode, please choose an open and wide space for the flight, and make sure that the satellite number is over 7.



- Please do not calibrate the compass in strong magnetic area, such as magnetic field, parking place or construction areas with underground reinforcement.
- Please do not carry magnetic materials with you (such as keys, cell phones, etc) when calibrating compass.
- Please keep away from big metal when calibrating compass.

### Gyroscope calibration

After the aircraft and the remote controller are banded, set the aircraft on flat ground and follow the indication photo as below to calibrate the gyro. Once the aircraft front lights turn from flashing to solid on, it means that the gyro calibration is succeeded.

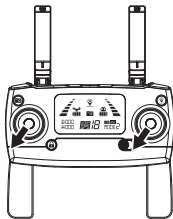

- The gyroscope calibration has been done by factory default. Gyroscope calibration is no need to be performed unless the aircraft can not exit the aircraft initialization detection procedure while the aircraft initialization detection is finished.
- Please make sure to set the aircraft on horizontal surface when performing calibration, failure to do this will affect the flight.

### How to lock and unlock the aircraft

- **Unlock the aircraft**  
Short-press the red button "🔒". The motors rotate and the aircraft is unlocked.
- **Lock the aircraft**



**There are 2 ways to lock the aircraft that you can find it as below:**

Method 1: Long-press the red button "🔒" for 3 seconds, the motors will stop rotating immediately and the aircraft is locked.

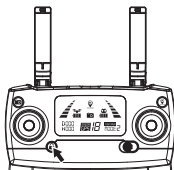







Method 2: After the aircraft lands on the ground, pull down the throttle stick to the bottom position and keep for 3 seconds, the motors will stop rotating and the aircraft is locked.

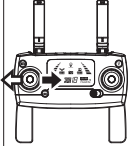

Warm tips:

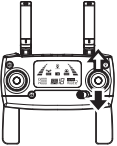
- Please do not lock the aircraft by pressing the “” button directly during the flight.
- In case that Emergency Stop on the aircraft is needed, please keep pressing the “” button for 3 seconds; then the aircraft will stop running and the aircraft will drop down.

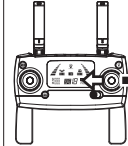
### Operate the aircraft

Remote controller	Aircraft	Remote controller	Aircraft
	<p>Ascent</p>  <p>Descent</p> 		<p>Turn Right</p>  <p>Turn Left</p>  <p>Front</p> <p>Rear</p>
	<p>Backward</p>  <p>Forward</p> 		<p>Leftward flight</p>  <p>Rightward flight</p>  <p>Front</p> <p>Rear</p>

---

## Test Flight

### Basic flight operation steps

1. Place the aircraft in a wide open area that its front is your front.
2. Turn on the aircraft and remote controller.
3. Connect the remote controller with the aircraft and then proceed aircraft initialization detection.
4. Connect the D88 with your phone and enter into the image transmission interface.
5. Unlock the aircraft after the gyro detection of the aircraft is completed.
6. Pull up the throttle stick then the aircraft takes off, and control the aircraft flight by left/right stick.
7. Pull down the throttle stick to land the aircraft.
8. Pull down the throttle stick to the bottom position and keep for 3 seconds to lock the aircraft.
9. Pull out the battery from the aircraft and then turn off the remote controller.

### Video suggestion and tips

1. Do pre-flight checklist;
2. Choose appropriate gimbal shooting angle;
3. Fly in a good weather with no wind;
4. Perform test flights to establish flight routes and to preview scenes;
5. Push the control stick gently to keep the aircraft movement smooth and stable.



Please bear proper operation and flight safety guidelines in mind as it is very important for all of us.

For more information, please turn to Appendix.

---

## Appendix

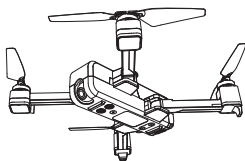

### Product Parameters

Aircraft	
Gross Weight (Battery and propellers included)	D88: about 640g
Dimensions	Folded: 190*130*75mm (length*width*height) Unfolded: 450*450*75mm (length*width*height)
Diagonal	350mm
Max Ascent Speed	3m/s
Max Descent Speed	2m/s
Max Speed	40km/h
Flight Height Limitation	150m
Max Flight Time	22 minutes (no wind)
Max Wind Speed Resistance	≤Level 3
Max Tilt Angle	35°
Max Angular Velocity	200°/s
Operating Temperature Range	0°C-40°C
GNSS	GPS
Hovering Accuracy Range	Indoor: Vertical ±0.3m Horizontal ±0.3m Outdoor: Vertical ±0.5m Horizontal ±1.5m

Operating Frequency	2.4-2.4835GHz 5.15-5.35GHz
Transmission Power (EIRP)	2.4GHz≤20dBm 5GHz≤16dBm
<b>Gimbal</b>	
Controllable Range	Tilt: -90° to 0°
<b>Camera</b>	
Image Sensor	1/3 " CMOS; Effective Pixel: 2 million
Lens	FOV: approx. 110° Aperture: f/2.4 Shooting Range: 1m to ∞
ISO Range	Photo: 100-1600 (Auto) Video: 100-1600 (Auto)
Electronic Shutter Speed	Electronic Shutter: 1/30s-1/10000s
Still Image Size	2048X1152
Still Photography Modes	Single Shot
Video Resolution	2K: 2048X1152
Color Mode	RGB Mode
Max Video Bitrate	Video 12Mbit/Transmission 2Mbit
Supported File System	FAT32
Photo Format	JPEG Format
Video Format	MP4, Compressed Format H.264
SD Cards	Support Class 10 Micro SD card up to 32G. ≥ Class 10 Micro SD Cards
Operating Temperature	0°C-40°C
<b>Remote Controller</b>	
Operating Frequency	2.4-2.4835GHz
Max Transmission Distance	1.6km
Operating Temperature	0°C-40°C
Battery	2* AA
Transmission Power (EIRP)	2.4GHz≤20dBm
Operating Current/Voltage	200mA@3V



Charger	
Input	Type C 1: 5V 2A Type C 2: 5V 2A
Charging Voltage	Battery 1: 3.8 2A Battery 2: 3.8 2A
Rated Power	15.2W
Charging Current	1.5A (Max) (Adaptor≥2A)
Aircraft Battery	
Capacity	3400mAh
Voltage	7.6V
Battery Type	LiPo 2S
Energy	25.84Wh
Net Weight	about 297g
Charging Temperature Range	5°C-40°C
Charging Time	270 minutes
APP	
APP Name	Potensic-M2
Image Transmission System	WIFI 5GHz
Real-time Image Transmission	720p@20fps
Latency	300-400ms
Required Operating System	iOS 9.0 or later Android4.4 or later

## Packing Detail

Full package includes the following parts.

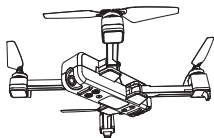

Aircraft \*1

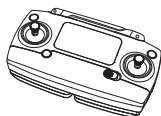

Remote Controller \*1



Extra Propellers Set \*1



Aircraft Battery \*1

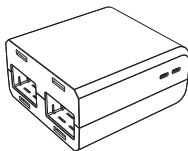

Charger x1



USB Cable x1

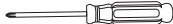

Screwdriver x1



Quick Start x1



User Manual x1

## Important Statement

- This aircraft is not a easy-to-play toy, but hobby grade model. It should be assembled and operated properly. Pilot must operate this aircraft in safe way. Improper operation may cause injury or property damage.
- This aircraft is applicable for pilots aged 14+ who are with skilled flying experience.
- Users are in full charge of proper operating this aircraft. Manufacturer and dealers disclaim any responsibility for damages caused by misuse.
- Keep the small accessories away from kids to avoid accident.

## Flight Safety Guidelines

Hobby grade radio control aircraft is somewhat considered to be the highest danger potential article. Users should firmly uphold the principle of "safety comes first". Never fly the aircraft near airports, above crowds or in zones storing dangerous goods and understand the responsibility of the accident may cause by improper operations.

- **Stay away from obstacles, crowds, power lines, trees or waters**

Always choose a wide open area for every flight, well away from people and property. Never fly directly over people or animals. Please don't fly in such bad weather conditions as high temperature, snow, strong wind (≥level 5), rain or fog. Maintain a 7ft (2m) distance from the aircraft when taking off and landing.

- **Keep the aircraft in dry environment**

The aircraft is composed by sophisticated electronic components and mechanical parts. To avoid damages on the mechanical and electronic components, please keep the aircraft in dry environment and use clean cloth to wipe the surface and keep it clean.

- **Practice flying together with skillful pilot**

Beginners are suggested to practice flying together with skillful pilot's guidance. Do not fly alone.

- **Bear proper operation and safe flight guidelines in mind**

Please take a careful look at the manuals before flights for important information of product functions and operation tips, and learn how to use the accessory, safe flight always comes first. Stay informed of and abide strictly by relevant local laws and regulations. Keep away from any non-flight zones and respect other people's privacy.

- **Safe flying**

Please make sure you are in good shape mentally before every flight. Fly the aircraft as per your flying experience. Never fly under influence of alcohol or drugs. Keep the remote controller at least 20 cm away from your body when flying the aircraft.

- **Keep distance from a flying aircraft**

Never use your hands to touch a flying aircraft under any circumstance. Don't approach and touch a landed aircraft before its propellers are completely locked.

- **Keep away from heat source**

The aircraft is made of metal, fiber, plastic, electronic component and other material. Please keep it away from the heat source to avoid deformation or even damage caused by sun exposure and high temperature.

- **Environmental protection requirements**

To protect our blue planet, so please recycle the aircraft as per local laws and regulations.

Note:

- a) Changes or modifications are not expressly approved by the party responsible for compliance could void the user's authority to operate the equipment.
- b) This equipment has been tested and found to comply with the limits for a Class B digital device, pursuant to part 15 of the FCC Rules. These limits are designed to provide reasonable protection against harmful interference in a residential installation. This equipment generates, uses and can radiate radio frequency energy and, if not installed and used in accordance with the instructions, may cause harmful interference to radio communications. However, there is no guarantee that interference will not occur in a particular installation. If this equipment does cause harmful interference to radio or television reception, which can be determined by turning the equipment off and on, the user is encouraged to try to correct the interference by one or more of the following measures:
- Reorient or relocate the receiving antenna.
  - Increase the separation between the equipment and receiver.
  - Connect the equipment into an outlet on a circuit different from that to which the receiver is connected.
  - Consult the dealer or an experienced radio / TV technician for help.

