

Bugs 3

MJX brushless drone Bugs 3

Instruction Manual



(Camera not included)



Brushless motor
(1800 1800KV)



Independent ESC
(automatic lock protection,
high temperature lock protection)



Two direction 2.4GHZ
(weak signal alarm, low voltage alarm)

Important statement and safety guidelines

Thank you for purchasing MJX product. Please read this manual carefully before use and retain it for future reference.

Important statement

- This aircraft is not a toy, but hobby grade model. It should be assembled and operated properly. Pilot must operate this hobby model in safe way. Improper operation may cause injury or property damage.
- This aircraft is applicable for pilots aged 14+ who are with skilled flying experience.
- Users are in full charge of proper operating this aircraft. Manufacturer and dealers disclaim any responsibility for damages caused by misuse.
- Keep the small accessories away from kids to avoid accident.

Flight safety guidelines

Hobby grade radio control aircraft is somewhat considered to be the highest danger potential article. Users should firmly uphold the principle of "safety comes first". Never fly the aircraft near airports, above crowds or in zones storing dangerous goods and understand the responsibility of the accident may cause by improper operations.

• Stay away from obstacles, crowds, power lines, trees or waters

Always choose a wide open area for every flight, well away from people and property. Never fly directly over people or animals. Please don't fly in such bad weather conditions as high temperature, snow, strong wind(≥level 5), rain or fog. Maintain a 7ft (2m) distance from the aircraft when taking off and landing.

• Keep the aircraft in dry environment

The aircraft is composed by sophisticated electronic components and mechanical parts. To avoid damages on the mechanical and electronic components, please keep the aircraft in dry environment and use clean cloth to wipe the surface and keep it clean.

• Practice flying together with skillful pilot

Beginners are suggested to practice flying together with skillful pilot's guidance. Do not fly alone.

● Bear proper operation and safe flight guidelines in mind

Please take a careful look at the manuals before flights for important information of product functions and operation tips, and learn how to use the accessory, safe flight always comes first. Stay informed of and abide strictly by relevant local laws and regulations. Keep away from any non-flight zones and respect other people's privacy.

● Safe flying

Please make sure you are in good shape mentally before every flight. Fly the aircraft as per your flying experience. Never fly under influence of alcohol or drugs. Keep the remote controller at least 20 cm away from your body when flying the aircraft.

● Keep distance from a flying aircraft

Never use your hands to touch a flying aircraft under any circumstance. Don't approach and touch a landed aircraft before its propellers are completely locked.

● Keep away from heat source

The aircraft is made of metal, fiber, plastic, electronic component and other material. Please keep it away from the heat source to avoid deformation or even damage caused by sun exposure and high temperature.

● Environmental protection requirements

To protect our blue planet, so please recycle the aircraft as per local laws and regulations.

Product profile

Product configuration

Product/spare parts included in the box

B3 fuselage(camera not included) X1	Battery x1	Protecting guard x4
Extra Propellers A/B X2	Charger x1	Propeller changing tool x1
High landing gear x4	Screw driver x1	Camera holder X1
Remote controller x1		

Technical parameter of the aircraft

Diagonal: 310mm

Overall height: 140mm

Brushless motor: 1806

Gross Weight: about 485g (with high landing gear, protecting guard, battery)

Battery: 7.4V1800 mAh

Charging Time: about 300 minutes

Maximum flying time: about 18 minutes (without mounting the high landing gear and protecting guard)

Product assemble

Propellers installation/removal

• Installation

Install propeller A and propeller B on the corresponding motor shaft and fix the rotor propellers tightly by rotating them as per the "lock" direction showed on the propellers.

• Removal

Fix the brushless motor by rotor blade changing tool and then rotate and remove the propellers as per the "unlock" direction showed on the propellers.

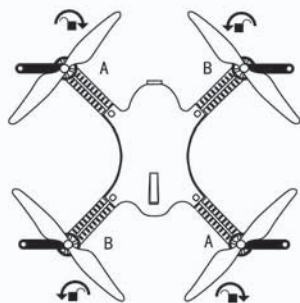
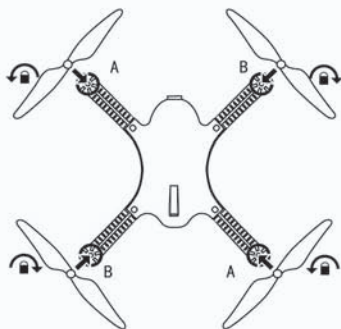

-
-  Please make sure that the clockwise and the counter clockwise propellers are installed on the correct motors, because the aircraft will not fly normally for wrong propellers installation.
 - Be careful when installing the propellers, as they are a little sharp.
 - Please use MJX propellers for this aircraft.
 - Extra propellers can be ordered additionally.
-

Protecting guard installation

First, release the two screws from the bottom of the motors. Then, install the protection guard on the corresponding position, and fix the screws in clockwise rotation.

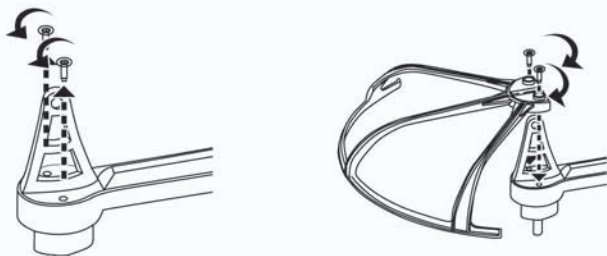

High landing gear installation

Insert the high landing gear plug into the socket locating at the bottom of the aircraft, align the 2 screws positions and fix the high landing gear by screwing clockwise.

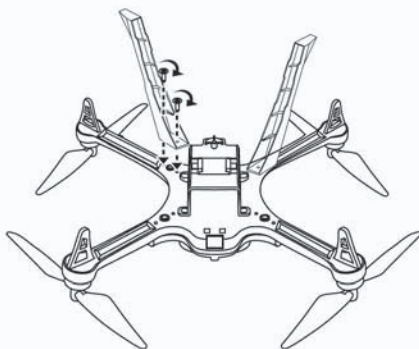

Battery installation

Insert the battery into the battery compartment and make sure the battery is installed in place. Then, insert the power plug of the battery into the power socket locating at the rear of the aircraft.

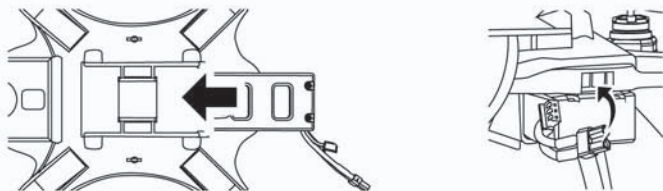

 **Note:** Please connect the power plug as per the indicated positive and negative polarity.

How to install the battery of remote controller

Unscrew counter clockwise to open the battery compartment cover, install 4x AA batteries into the battery compartment according to the given polarity, screw clockwise to close the battery compartment.

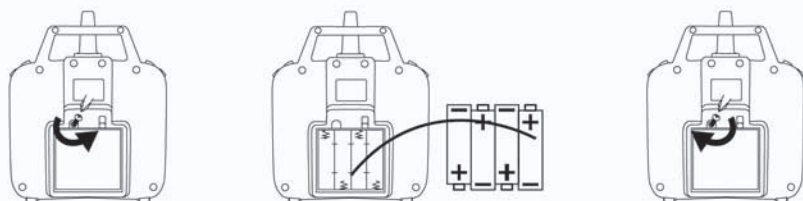

-
- ⚠** • Insert batteries with correct polarity.
- Non rechargeable batteries are not to be charged; the transmitter need 4 X AA batteries for work.
 - Do not mix old and new batteries.
 - Do not mix alkaline, standard(carbon-zinc), or rechargeable(nickel-cadmium) batteries.
 - Rechargeable batteries are to be removed from the toy before being charged;
 - Rechargeable batteries are only to be charged under adult supervision;
 - Exhausted batteries are to be removed from the toy;
 - The supply terminals are not to be short-circuited.
-

How to charge the battery of model

Insert the charger plug to the power outlet, the charger indicator turns green; then, connect the triple-lines plug of the battery with the charger power line to charge the battery. The charger indicator keeps red when charging is proceeding and turns green once the battery is full charged. Charging time is about 300 minutes.

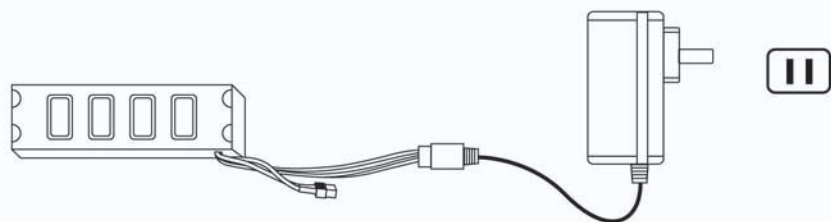

- ⚠** •Need adult supervision when this model is being played by children.
- Only batteries of the same or equivalent type as recommended are to be used.
 - Insert batteries with correct polarity.
 - Non rechargeable batteries are not to be charged; the transmitter need 4 X AA batteries for work.
 - Do not mix old and new batteries.
 - Do not mix alkaline, standard(carbon-zinc), or rechargeable(nickel-cadmium) batteries.
 - Rechargeable batteries are to be removed from the toy before being charged.
 - Rechargeable batteries are only to be charged under adult supervision.
 - Exhausted batteries are to be removed from the toy.
 - The supply terminals are not to be short-circuited.
 - The charging line to be used with the product should be regularly examined for potential hazard,such as damage to the cable or cord, plug,enclosure of other parts and that in the event of such damage,the product must not be used until that damage had been properly removed.

Major parts of the model

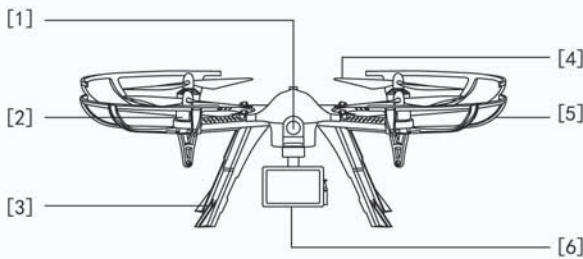

- [1] Front light
- [2] Brushless motor
- [3] High landing gear
- [4] Propeller
- [5] Protecting guard
- [6] Camera mount

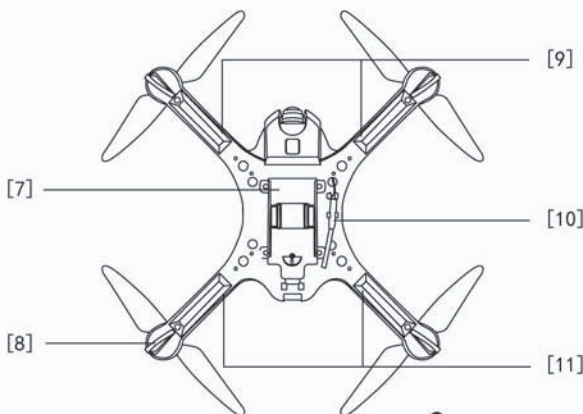

- [7] Battery compartment
- [8] Bottom landing gear
- [9] Front indicator light
- [10] Antenna
- [11] Rear indicator light

Major parts of the remote controller

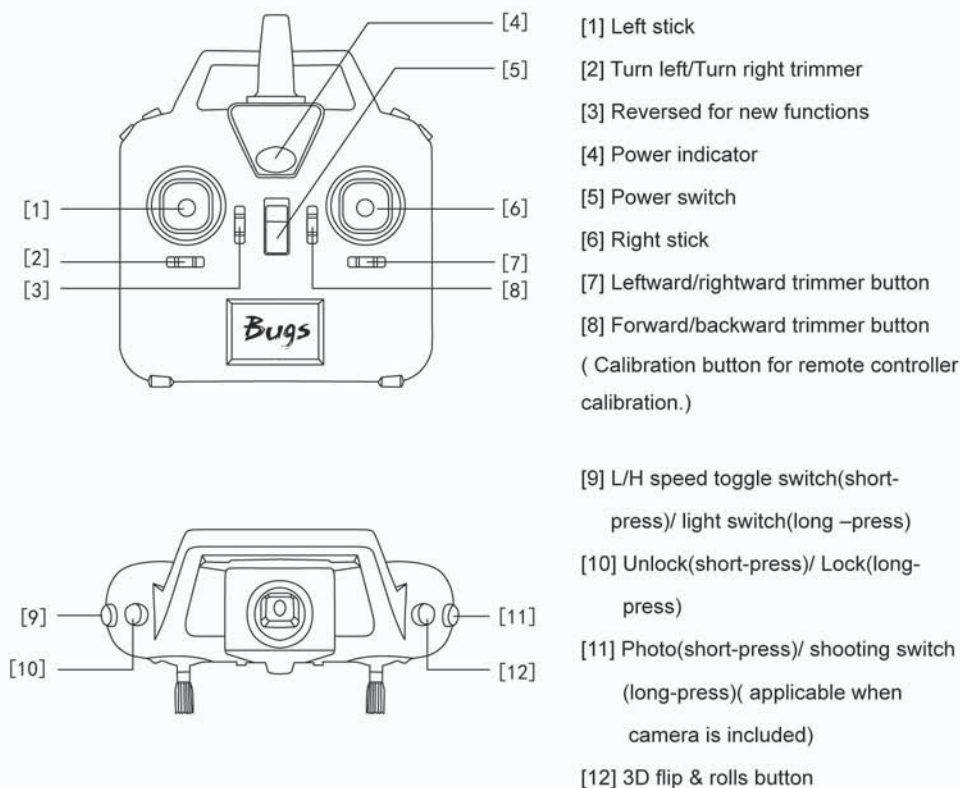

Remote controller

Remote controller calibration

Turn on the remote controller. Push down the calibration button and hold on for 3 seconds. The remote controller will send out 3 beep sounds; the indicator light of the aircraft turns from flashing quickly to slowly. Maximum rotate both of the left and right control stick to any direction for 2 circles. Then, again, push down the calibration button and hold on for 3 seconds. The remote controller will send out 3 beep sounds; the indicator light of the model turns from flashing slowly to quickly, which means that remote controller calibration is completed.

Warm tips:

- All remote controllers have been calibrated when manufacturing.
- Remote controller calibration is requested only if pilots find that the remote controller control sticks are not working normally.

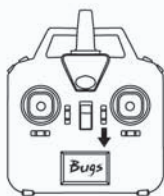

How to connect the signal of the aircraft with the remote controller

- Press the red button on top of the remote controller and turn on the power of the remote controller. The remote controller will send out 2 beep sounds, and the indicator lights keeps flashing, the remote controller is under signal connection status.
- Turn on the aircraft. Once signal connection is done. The remote controller will send out a long beep sound and the indicator light keeps solid green.



- ⚠ • Signal connection is done once for all if it is not connected with other aircraft.
- Set the connection one by one to avoid signal connection error.

Aircraft calibration

Once the gyro detection of the aircraft is finished, push down both of the control sticks to the lower right corner (indicated as below photo). The aircraft front lights turn from solid to flashing. It means that aircraft calibration is succeeded.

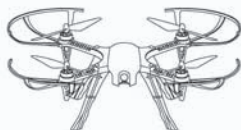

How to lock and unlock the aircraft

Unlock the aircraft

Once the gyro detection of the aircraft is finished, the front lights of the aircraft keep solid. After a long beep sound from the remote controller, the rear lights of the aircraft keep solid, as well. And the motors rotate slowly, the aircraft is unlocked.

Lock the aircraft

Pull down the throttle stick to the bottom position, long-press the red button (indicated as below photo). The remote controller sends out interrupted beep sound. Then, the motors stop rotating and the rear indicator light is off, which means that the aircraft is locked.

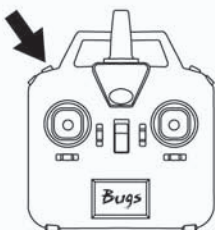

⚠ Warnings: The throttle control stick should be pushed to the bottom position when long-press the red button to lock the aircraft. Otherwise, the aircraft could not be locked.

Operate the aircraft

Remote controller	Aircraft	Remote controller	Aircraft
A line drawing of the remote controller. The throttle stick is pushed up, and the left joystick is pushed to the left.	A line drawing of the aircraft from a top-down perspective. An upward arrow is above the aircraft and a downward arrow is below it.	A line drawing of the remote controller. The left joystick is pushed to the right and the right joystick is pushed to the left.	A line drawing of the aircraft from a top-down perspective. Two curved arrows indicate the aircraft is rotating.
A line drawing of the remote controller. The throttle stick is pushed up and the right joystick is pushed up.	A line drawing of the aircraft from a top-down perspective. Two curved arrows indicate the aircraft is rotating.	A line drawing of the remote controller. The left joystick is pushed to the right and the right joystick is pushed to the right.	A line drawing of the aircraft from a top-down perspective. Two curved arrows indicate the aircraft is rotating.

Flips & rolls

Flips & rolls operation



Warm tips:

To flip and roll, please press down the 3D rolling button and push the direction control stick at the same time. If not, the aircraft could not perform flips & rolls action normally.

How to fine-tune the aircraft

If the model keeps moving in any direction even this is no control signal given after flying, users may adjust the remote controller's trimmer button to keep the model balance.

Forward/backward trimmer

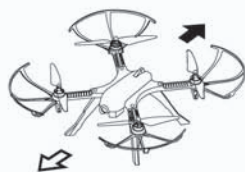

Turn left/ turn right trimmer

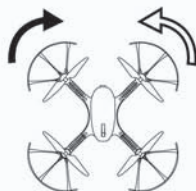
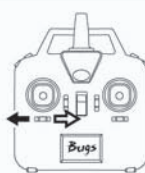

Leftward/rightward trimmer

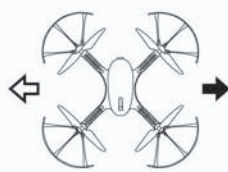
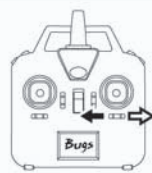

Aircraft indicator light description

Status	Description
Front light is flashing quickly.	Gyro of the aircraft is in signal detecting condition.
Front light is flashing on twice and flashing off two second.	The aircraft haven't received signal from the remote controller.
Front light is flashing on once and flashing off two second.	The signal of remote controller is lost after the aircraft received the signal from the remote controller.
Front light is flashing slowly or front/back light are flashing at the same time.	The aircraft is underpowered and the remote controller send out the sound "beep,... beep,, beep,...".
Front light is on all the time, back light is off.	The aircraft is under lock status.
Front and rear light are both solid on.	The aircraft is under unlocking or flying status.

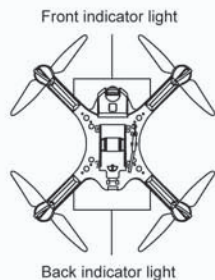

Remote controller power indicator light description

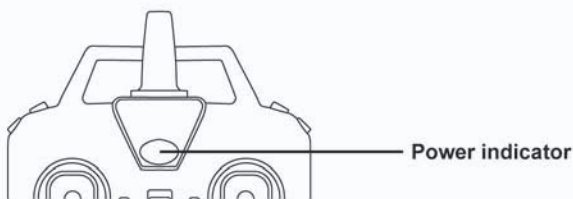

Remote controller sound	Power indicator	Description
Send out continuous beep sound quickly	On	1. The aircraft is too far away from the remote controller that resulted in weak receiving signal. 2. The aircraft is powered off after successful signal connection.
Send out continuous beep sound slowly	On	The aircraft is in low voltage status.
Send out a long beep sound only	On	The remote controller has connected with the aircraft successfully.
Send out "beep beep" sound continuously	Flashing slowly	The aircraft is under power.
Send out "beep" occasionally	On	The aircraft receives very weak signal from the remote controller.

Flight

Before you take off, check and make sure that:

- 1.The aircraft and the remote controller are full charged.
- 2.The propellers are installed correctly.
- 3.The motors work normally after unlocking.

Basic flight operations

Basic flight operations step

1. Connect the remote controller with the aircraft.
2. Unlock the aircraft after the detection of gyro of the aircraft is completed.
3. Pull up the throttle stick then the aircraft takes off, remote control the flight aircraft by left/right stick.
4. Push the throttle stick to the bottom, lock the aircraft by press the lock button for long time.
5. Take out the battery from the aircraft.



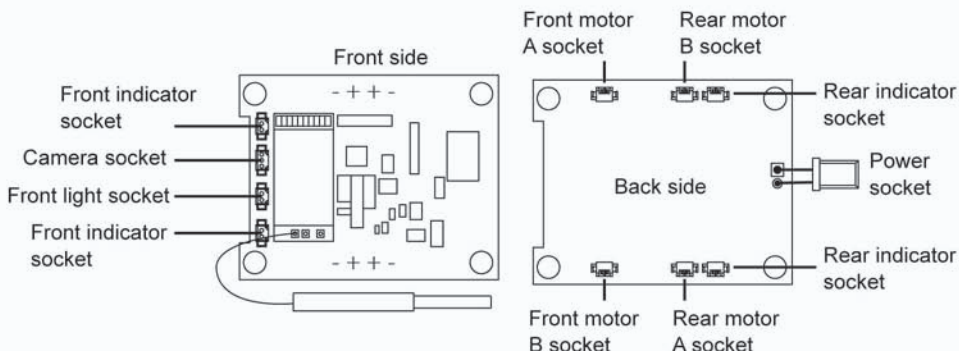

Receiver PCB connecting diagram

To make the model operate normally, the receiver PCB's installation direction and the insertion line's connecting position must be the same as below photo showed.



Product components

Basic parts

			
Upper cover B30001	Main frame B30002	Protecting guard B30003	Bottom landing gear B30004

			
Propeller A/B B30005	High landing gear B30006	Transparent plastic part B30007	Battery compartment component B30008
			
Front light component B30009	ESC B30010	Front/back light strip B30011	Receiver PCB B30012
			
Screws pack B30013	Clockwise motor B30014	Counter clockwise motor B30015	Heat sink B30016
			
Propeller changing tool B30017	Battery B30018	Instruction manual B30050	Color box B30051
			
Plastic foam B30052	Camera mount 401101	Charger	

Spare parts available to upgrade B3

			
WIFI Camera C4020	360° Panoramic WIFI Camera C4022	MJX VR goggles G2	5.8G FPV Camera C5820
			
5.8G Receive screen 4.3-inch LCD Display D43	5.8G Receive screen 7-inch LCD Display D70	MJX FHD sport camera C4000	

Trouble shooting

No.	Phenomenon	Solution
1	The lights are flashing quickly	The Gyro of the model is under signal detecting condition, set the model to any flat surface
2	The model can't be kept balance after taking off and lean one side	1) Adjust all trimmer buttons to the middle value. 2) Lay the model in the flat surface or flat ground and proofread the gyro of the model again
3	The model is shaking fiercely	The rotor blade is out of shape, change the propellers
4	The model can't be unlocked, front indicator light flashes slowly	The battery is under low power situation, please charge the battery full
5	The model can't be locked	1) Push the throttle stick to the bottom first, then press the lock button for long time 2) Proofread the stick of the remote control then push the throttle stick to the bottom, later press the lock button for long time

- Note: a) Changes or modifications not expressly approved by the party responsible for compliance could void the user's authority to operate the equipment.
- b) This equipment has been tested and found to comply with the limits for a Class B digital device, pursuant to part 15 of the FCC Rules. These limits are designed to provide reasonable protection against harmful interference in a residential installation. This equipment generates, uses and can radiate radio frequency energy and, if not installed and used in accordance with the instructions, may cause harmful interference to radio communications. However, there is no guarantee that interference will not occur in a particular installation. If this equipment does cause harmful interference to radio or television reception, which can be determined by turning the equipment off and on, the user is encouraged to try to correct the interference by one or more of the following measures:
- Reorient or relocate the receiving antenna.
 - Increase the separation between the equipment and receiver.
 - Connect the equipment into an outlet on a circuit different from that to which the receiver is connected.
 - Consult the dealer or an experienced radio/TV technician for help.

