

X220 v2 User Manual

catalogue

1 product introduction	3
2 Remote Control Radio Transmitter	4
2.1 Buttons and switches.....	4
2.2 Basic operation.....	5
2.3 Joystick functions.....	5
2.4 Display.....	7
3 Flight Guide	9
3.1 Safety instructions.....	9
3.2 Arm/disarm and flight modes.....	9
3.3 Basic operation of drone.....	10
3.3.1 Power the drone.....	10
3.3.2 Replacement of propeller.....	10
3.4 Binding.....	11
3.5 Pre flight inspection.....	11
3.6 Frist fly.....	12
3.7 Warning&security.....	12
4 Battery	14
4.1 Battery voltage.....	14
4.2 Charging method.....	14
4.3 Preservation method.....	14
4.4 Warning&security.....	15
5 Advanced operations	16
5.1 Flight controller wiring diagram.....	16
5.2 Equipment wiring diagram.....	16
5.3 Fpv fly.....	18

1 product introduction

Components

x220 v2 RTF

FLYSKY I6X Remote Control Radio Transmitter

Package Included:

1 x X220 V2 Frame Kit

1 x Flysky FS-i6X Remote Control

1 x Flysky FS-A8S Receiver

1 x 1500mAH 4S 14.8V Battery

2 x 2207 2550KV Motor CW

2 x 2207 2550KV Motor CCW

1 x PDB-XT60

1 x F405 DJI DUAL BEC V1 Flight Controller

4 x 30A Independent ESC

1 x FOXEER Arrow MICRO PRO Camera

1 x TC5804 PRO VTX

4 x 5046 3-blade Propeller CW

4 x 5046 3-blade Propeller CCW

1 x 30° Camera Mount (For Gopro5/6/7)

1 x Charger

1 x Antenna

2 x Battery Strap

2 x Carbon Wrench

2 Remote Control Radio Transmitter

2.1 Buttons and switches

The functions of switches, buttons and buttons are shown in the figure below :

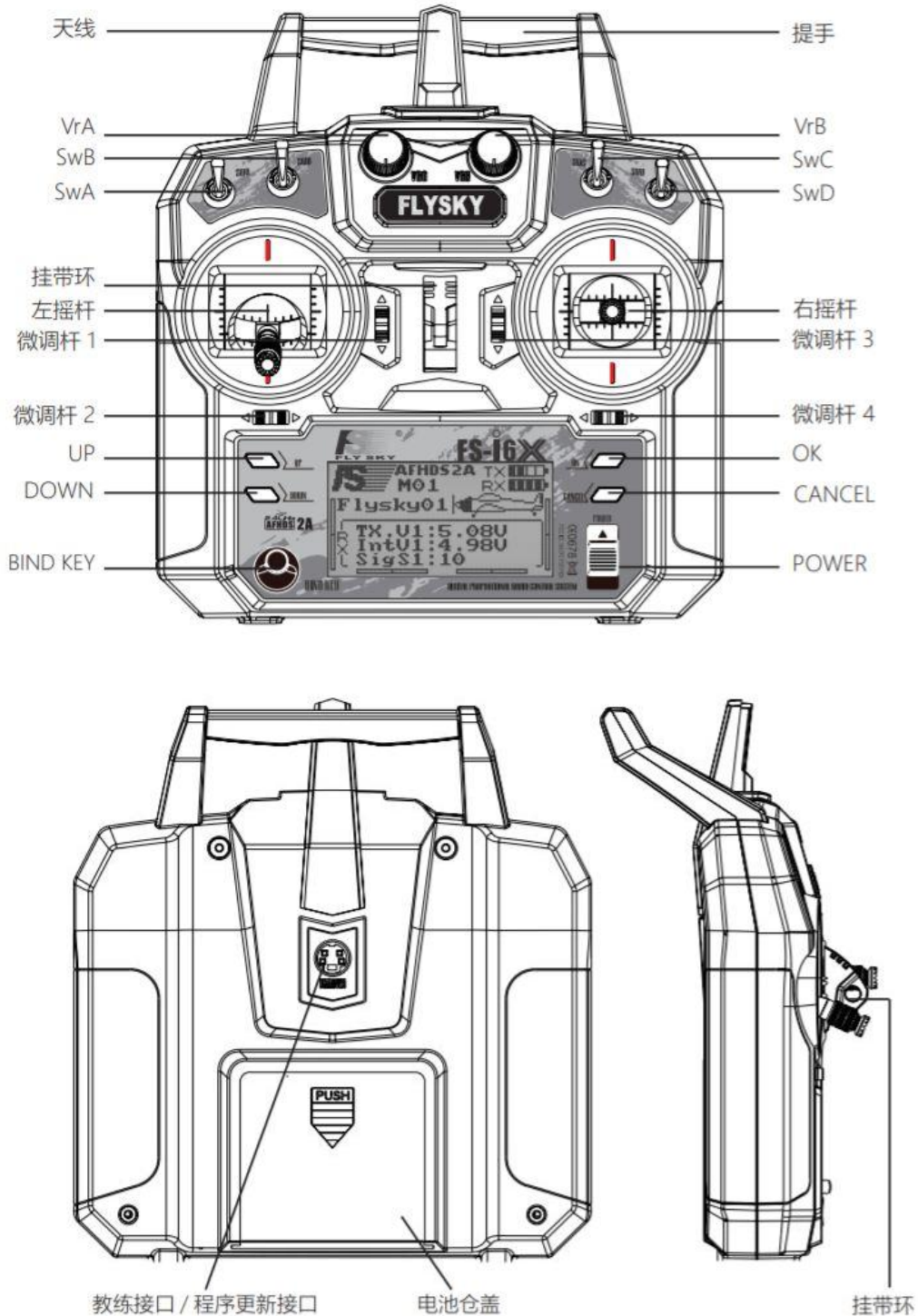

2.2 Basic operation

Turn on / off the remote control: push the power switch

Install the battery: open the battery compartment cover on the back of the remote control and install the battery

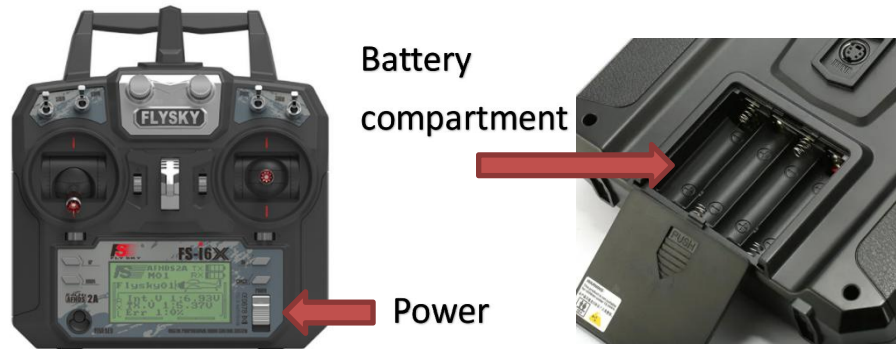

2.3 Joystick functions

joystick operation is divided into left throttle and right throttle, please check according to the type of your purchase..

2.3.1 left throttle

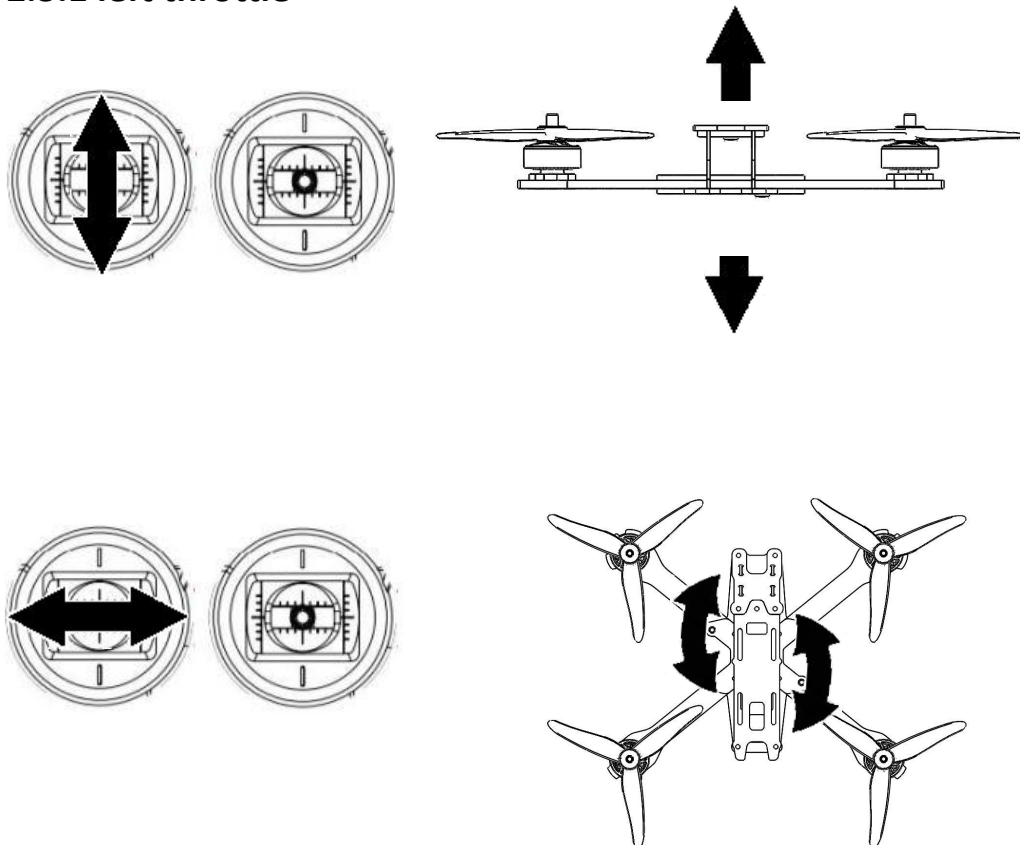

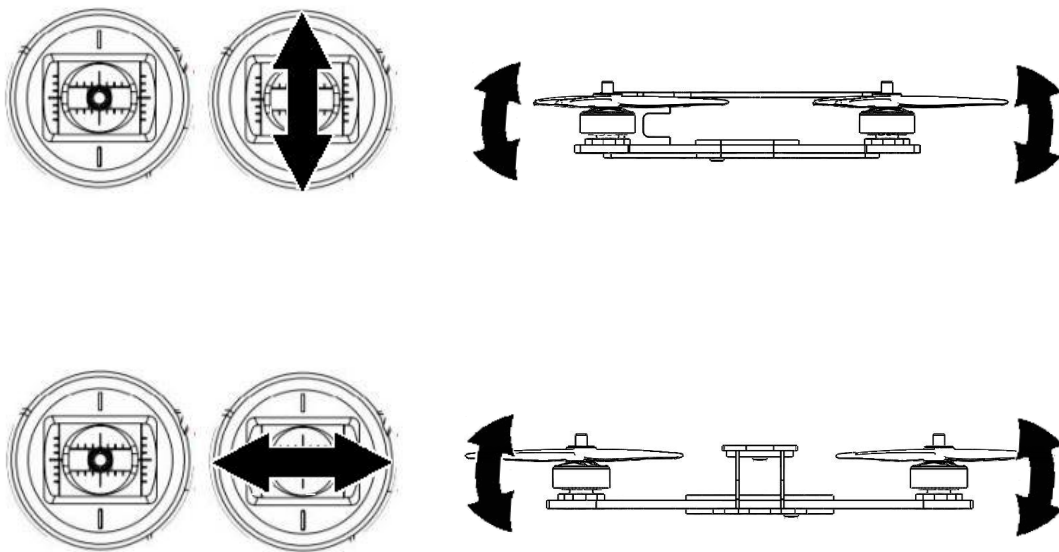

As shown in the figure above:

Left joystick :

Up and down for Throttle, control the drone ascent or descent

Left and right for Yaw , Control the drone to turn left or right

Right joystick :

Up and down for Pitch , Control the drone to lean forward or backward

Left and right for Roll , Control the aircraft to tilt left or right

2.3.2 right throttle

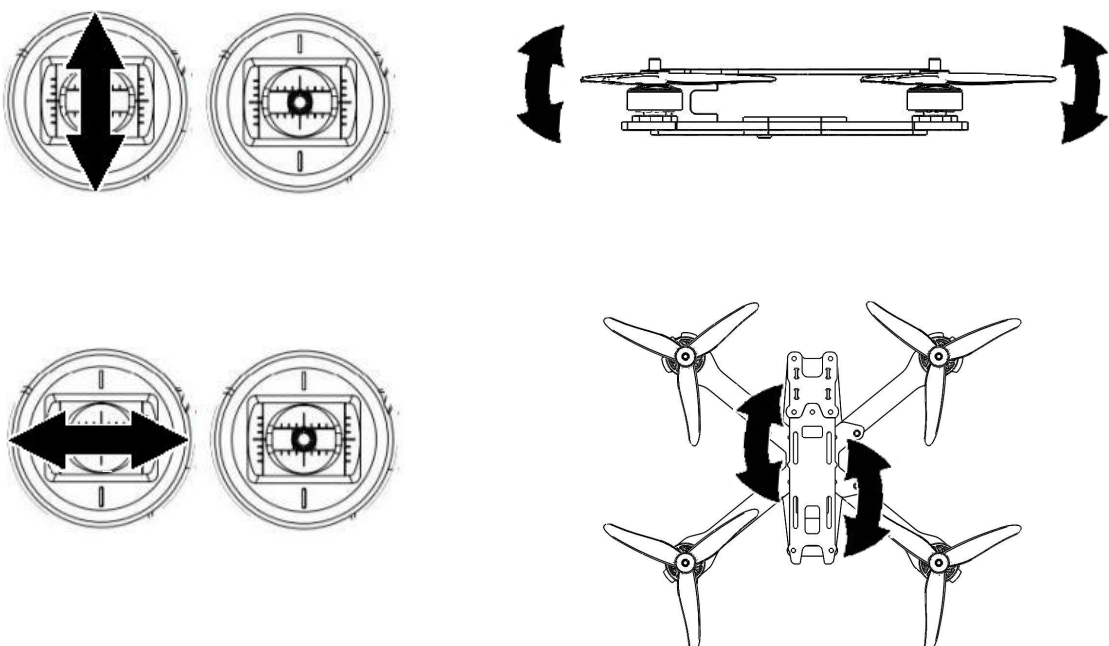

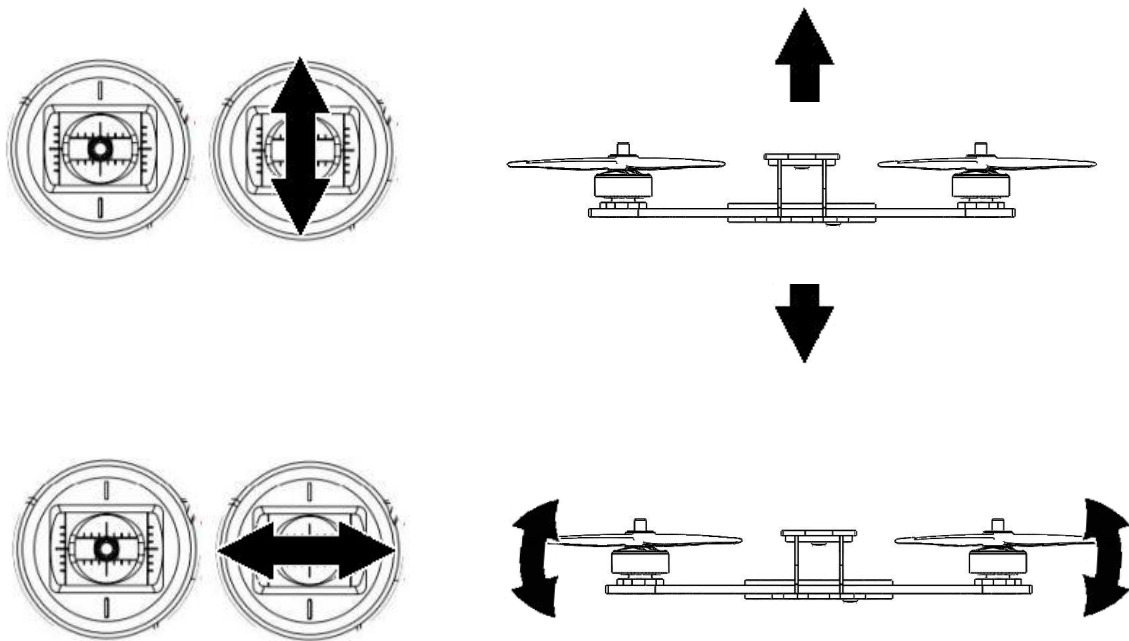

As shown in the figure above:

Left joystick :

Up and down for Pitch , Control the drone to lean forward or backward

Left and right for Yaw , Control the drone to turn left or right

Right joystick :

Up and down for Throttle, control the drone ascent or descent

Left and right for Roll , Control the aircraft to tilt left or right

2.4 Display

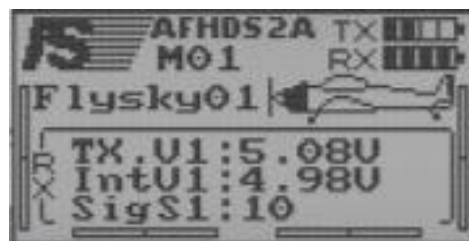

Tx : The voltage of the Transmitter

Rx : Voltage of receiver (If the drone and Transmitter not connected

successfully , it does not display)

Sig : signal intensity

3 Flight Guide

So far, you have the necessary understanding of transmitter and drone, you can start from the flight guide

3.1 Safety instructions

The flight of the drone must comply with local laws and regulations!
Keep a safe distance in all directions around the drone to avoid collision.
Operate a drone in an open space away from people and traffic.

3.2 Arm/disarm and flight modes

Arm : The motor rotates at idle speed, and the drone can be controlled at this time

Disarm : The motor of the aircraft stops immediately, and the drone cannot be controlled at this time

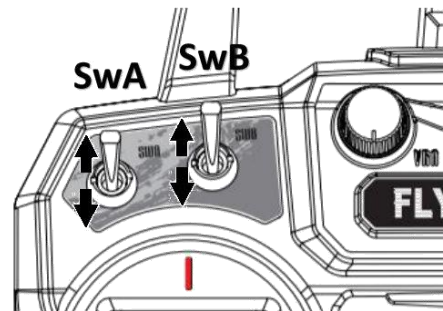

Switch SA:Arm/Disarm of drone

Drone will be disarmed if SA is down

Drone attempts to arm if the user moves switch SA up (Arming may fail If the throttle is not at the lowest position)

To ensure your flight experience, the drone has two flight modes:

Level mode :

The joysticks controls the current tilt angle of the drone. The drone will return to horizontal flight when the joysticks are centered, Recommended for beginners.

ACRO mode:

The joysticks controls the rotation speed of the drone. When the joystick is centered, the drone will maintain its current angle.

Switch SB:Level/Arco mode

The flight mode is "level mode".If the switch SB is down

Theflight mode is "acro mode"If switch SB is up

3.3 Basic operation of drone

3.3.1 Power the drone

Strap the battery to the upper cover plate of the drone, connect its XT60 plug to the same plug of the aircraft, the flight control indicator lights up, and the power supply of the drone is successful

Warning⚠ :

In the case of non immediate flight such as drone maintenance, please remove the blades when connecting the battery.

3.3.2 Replacement of propeller

Grasp the motor by hand, use the matching wrench to remove the blade nut, pull out the blade, and replace it according to the figure below.

The blade is sharp. Pay attention to safety when disassembling the blade. Other tools can be used if necessary.



3.4 Binding

This kit has completed the frequency matching between the transmitter and the receiver. If you want to use another receiver or repeat bind, please follow the following steps:

1. Turn on the transmitter power and press the bind key to enter the code matching state.



2. Press and hold the bind key on the receiver, and connect the power to the receiver. The flash of the indicator light on the receiver indicates that the receiver enters the code matching state; After successful bind, the status indicator of the receiver changes from fast flashing to slow flashing.

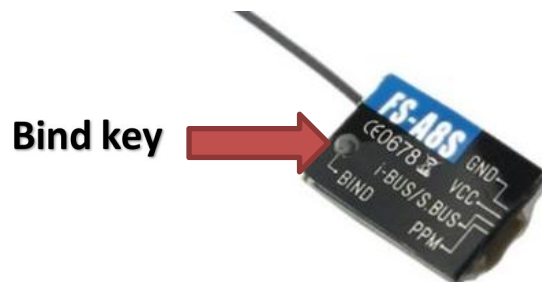

3. Exit the transmitter from the binding interface manually, and the status indicator of the receiver will be on.

4. Check whether the transmitter, receiver and model work normally. If there is any abnormality, repeat the above steps to re code.

3.5 Pre flight inspection

Make sure that all components are included and not damaged, and the battery is installed firmly.

Confirm that the propeller and motor are installed correctly.

Make sure that the propeller does not scratch any parts.

Make sure that the transmitter and the receiver are correctly connected

Verify that (drone, transmitter) is fully charged.

Make sure you are familiar with all flight controls.

3.6 Frist fly

When everything is ready, you can start to enjoy flying

Return the throttle joystick to lowest position (refer to Section 2.3), turn on the transmitter and check that the switch SA is down

Install and power up batteries for the aircraft

1. After confirming the safety of the environment, turn the switch SB down (arm the drone) and start your flight

2.For the first flight, please push the throttle joystick slowly and gently to control the drone to hover stably in front of you to adapt to the sense of control. The tail is always facing you. When you can hover stably and control skillfully, slowly increase the flight distance

3.7 Warning&security

1. If the drone collides with any object, turn the switch SA down (disarm the drone) **immediately**.

2.Learn to control drone **skillfully** before flying in a larger area.

3. Battery life will be **significantly shortened** If you continue to fly after displaying the low voltage warning

5 Keep the UAV away from water and **do not** fly in the rain. If the equipment touches water, it may be damaged by short circuit.

6.**Do not** fly in bad weather.

7.**Do not** fly in areas not allowed by local law.◦

4 Battery

4.1 Battery voltage

The battery consists of four cells. The single cell voltage of the battery needs to be kept above 3.5V (14v for one battery) at all times and 4.2V (16.8v for one battery) is full charge. Excessive charge or discharge will cause serious damage to the battery. Please use the charger included in the package for charging

4.2 Charging method

The charger included in the product has the functions of overcharge protection and balanced charging. You can use the charger directly. The usage is as follows:

Connect the charger to the power supply and connect the battery to the charger

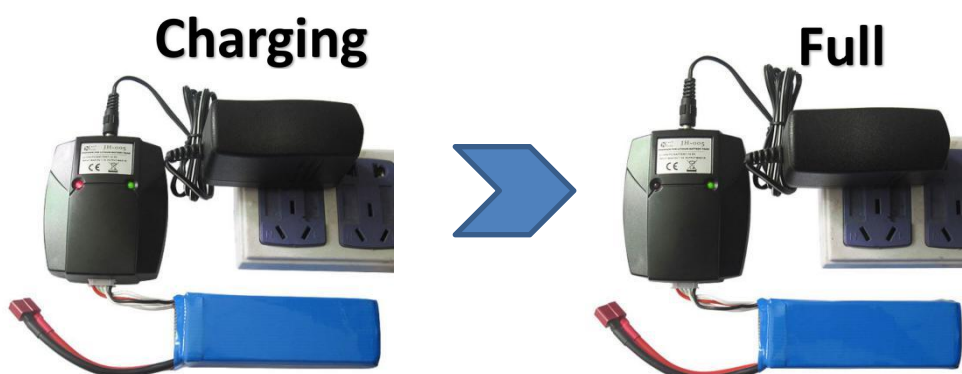

When the charger is not charged, the green light will be on; when it is charged, the red light will be on; when it is full, the red light will be off

4.3 Preservation method

When the battery is not used for a long time, the storage voltage should be kept at about 3.85v (15.4v for one battery) for a single cell, and it should be placed in a cool and dry place

4.4 Warning&security

Stay away from children. If swallowed, seek medical attention immediately.

Do not use or store the battery near the heat source, microwave oven or open fire. Do not damage the battery violently..

Only use battery chargers that meet the specifications when charging.

Do not use or store the battery in extremely hot environment, such as in a car in direct sunlight or hot weather. Overheating will affect the performance of the battery and shorten the service life of the battery. Overheated batteries can also catch fire.

If the battery has peculiar smell, heating, deformation, discoloration or other abnormal phenomena, please stop using the battery. Recycle and replace the battery.

Discarding batteries at will may cause a fire. Before disposal, discharge the battery completely and handle the battery output connector with insulating tape. Refer to local regulations before handling or recycling batteries.

5 Advanced operations

5.1 Flight controller wiring diagram

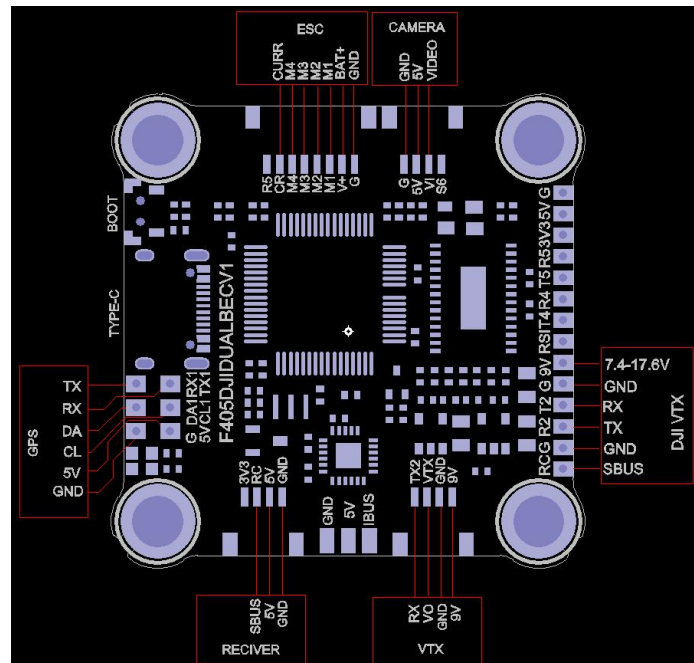

This wiring diagram is only provided to players with rich experience, proficient in circuit knowledge and welding skills.

You can add or change your Equipment according to this wiring diagram, but we do not recommend it.

5.2 Equipment wiring diagram

This product only uses the flight control and PDB shown in the figure below. Other equipment are used for demonstration. When you receive the drone , all the required equipment has been installed.

5.3 Fpv fly

This drone includes the video transmitter for FPV flight. You can experience FPV flight after purchasing FPV glasses. The following is the description of the video transmitter in this product

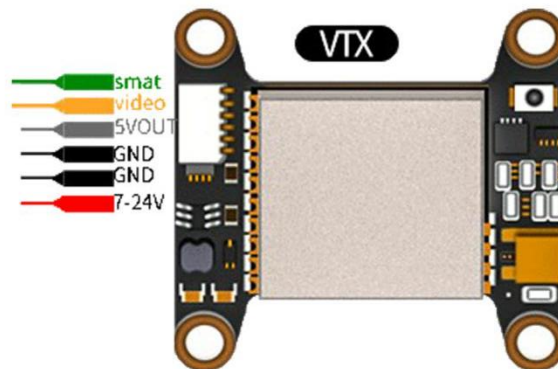
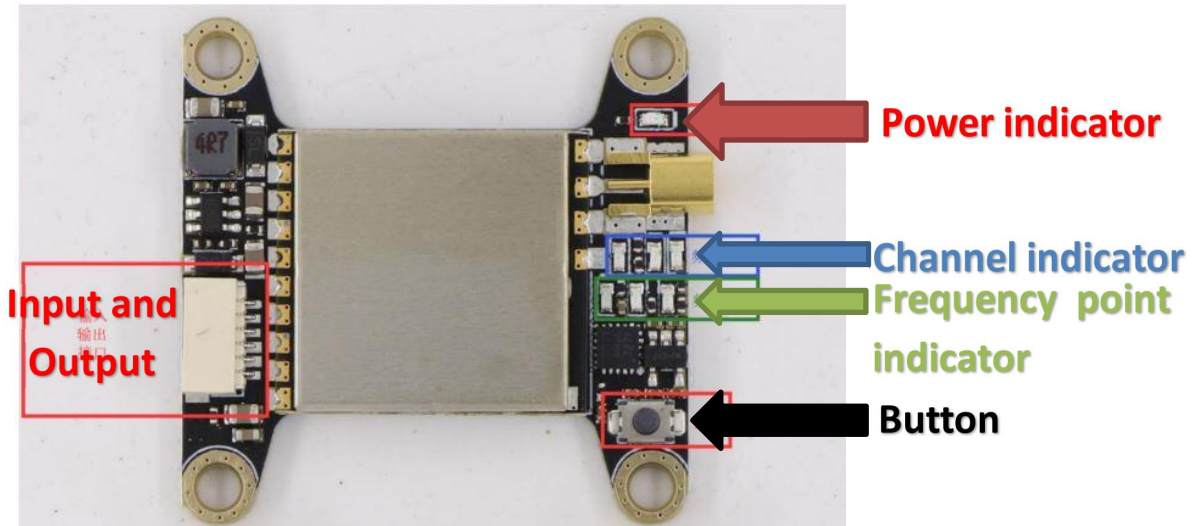

1. Use the buttons to change the power

Long press the button for 10 seconds, then short press to switch the power to 25MW / 200MW / 600MW

	25mW	200mW	600mW
FR LED	○ ○ ●	○ ● ○	● ○ ○
CH LED	○ ○ ●	○ ● ○	● ○ ○

Solid circle means light on, hollow circle means light off

The power indicator shows the current power :

	25mW	200mW	600mW
Power indicator	Flash 1 , stop 3s	Flash 2 , stop 3s	Flash 3 , stop 3s

2. Use the buttons to change the power

Long press the button for two seconds, then short press to change the channel

Press the key again for two seconds and then press the key to change the frequency

CH FR		CH1	CH2	CH3	CH4	CH5	CH6	CH7	CH8
		○○○	○○●	○●○	○●●	●○○	●○●	●●○	●●●
A	○○●	5865	5845	5825	5805	5785	5765	5745	5725
b	○●○	5733	5752	5711	5790	5809	5828	5847	5866
C	○●●	5705	5685	5665	5645	5885	5905	5925	5945
d	●○○	5740	5760	5780	5800	5820	5840	5860	5880
E	●○●	5658	5695	5732	5769	5806	5843	5880	5917
F	●●○	5362	5399	5436	5473	5510	5547	5584	5621

Solid circle means light on, hollow circle means light off

appendix :

Detailed parameters of equipment :

Brand: Eachine

Item Name: Wizard X220 V2 5 Inch 4S FPV Racing Drone PNP

Drone Weight: 407g (with Camera Mount)

Frame Kit	Wheelbase: 225MM Floor thickness: 2.0MM Upper board thickness: 2.0MM X board thickness: 2.0MM The thickness of the side panel of the camera: 1.5MM Arm thickness: 5.0MM Frame material: T300 carbon fiber
Motor	Motor KV: 2550RPM/V No-load current (I ₀ /10V): 1.35A Adipocytes: 3-5S Weight: 31 grams Maximum continuous current: 35A Maximum continuous power: 560W Maximum thrust: 1180g (4S/5") Configuration: 12N/14P Motor resistance R _M : 0.0536Ω Stator diameter: 22mm Stator thickness: 7mm Motor diameter: 27.7mm Length of motor body: 19.2mm Total shaft length: 34.2mm Drive shaft: M5 Bolt hole spacing: 16mm

	<p>Bolt thread: M3</p> <p>Propeller: 5-6 inches</p>
PDB-XT60	<p>Mount holes:30.5x30.5mm</p> <p>BEC:NO</p>
<p>F405</p> <p>DJIDUAL BEC</p> <p>V1 Flight</p> <p>Controller</p>	<p>CPU: STM32F405RGT6</p> <p>Six axis: MPU6000</p> <p>Mount holes: 30.5x30.5mm</p> <p>Size: 37mm x 37mm</p> <p>barometer : BMP280</p> <p>BEC : 5V/3A,9V/2A</p> <p>Balck box : 16M</p> <p>Firmware version: EachineF405 (STM32F405)</p> <p>OSD: Built-in BetaFlight OSD (STM32 controls the OSD chip through SPI in DMA mode)</p> <p>Receiver: Support Frsky XM / XM + receiver / for Futaba receiver / Flysky receiver / TBS Crossfire receiver / DSMX receiver</p>
<p>30A</p> <p>Blheli_S 2-4S</p> <p>ESC</p>	<p>Support PWM, Oneshot125, Oneshot42, Multishot, Dshot300, Dshot150, Dshot600</p> <p>Input voltage: 2S-4S Lipo</p> <p>Continuous current: 30A</p> <p>Peak current: 35A</p> <p>Firmware: BLHELI-S GH-30</p>
<p>FOXEEER</p> <p>Arrow MICRO</p> <p>PRO Camera</p>	<p>Image sensor: 1/3 inch SUPER HAD II CCD + Nextchip</p> <p>2040 DSP</p> <p>Pixel: PAL: 976 (H) x494 (V)</p> <p>P/n system: PAL</p> <p>Resolution: 600TVL (color) 650TVL (black and white)</p> <p>Synchronization: internal</p> <p>Minimum illumination: 0.01Lux</p>

	<p>WDR: Support</p> <p>OSD programming board: Support</p> <p>Noise repair: Support</p> <p>DNR: 2D DNR</p> <p>Camera title: Support</p> <p>Image adjustment: Support</p> <p>OSD: Edit name, power, flight time</p> <p>Input power: 5-40V</p> <p>Storage temperature: -40°C ~ 60°C</p> <p>Working temperature: -10°C ~ 50°C</p> <p>Power consumption: 70mA</p> <p>Low pressure alarm: Support</p> <p>Preset modes: DEF, VIVID, SUNY, CLOUDY, LED TR, USR1</p> <p>Size: 21.8x21.8mm</p> <p>Weight: 8.7g (not including stand)</p>
<p>TC5804 PRO VTX</p>	<p>Product name: 5.8G 40CH 0mW / 25mw / 200mw / 600mw VTX switchable</p> <p>Output power and transmission distance: $\geq 0.5\text{km}@25\text{mW}$, $\geq 1\text{km}$ to 200mW, $\geq 2\text{km}$ to 600mW</p> <p>Transmitting power: 0mW / 25mW / 200mW / 600mW</p> <p>Full movie format: NTSC / PAL</p> <p>Input voltage and power consumption: 7V~24V, +12V / 260mA @ 600mW</p> <p>Protocol: SmartAudio</p> <p>Size: 36 * 36 * 6mm</p> <p>Weight: $\leq 7\text{g}$ (not including antenna)</p> <p>With output power self-check function.</p> <p>Digital tube scanning: frequency point (1-8), frequency band (AE), power (1-3, 0 = 0mw, 1 = 25mw, 2 = 200mw, 3 = 600mw)</p> <p>Weight: 4.5g</p>

<p>RACERSTA R-5046 Propeller</p>	<p>Brand Name: Racerstar Model: Tornado 5046 Quantity: 4 CW/4 CCW Color: transparent black Material: PC Root thickness: 7mm Mounting shaft: 5mm Maximum propeller width: 17.5mm Length: 5 inches Weight: 5g</p>
<p>1500mAH 4S 14.8V Battery</p>	<p>Capacity(mAh) : 1500 Cells (s): 4 Weight (g): 143 Length(mm): 70 Width(mm): 335 Height(mm): 32 Connector: XT60</p>
<p>FLYSKY I6X remote controller</p>	<p>Item: FS-i6X RC Transmitter Channel: 6-10 (Default 6CH) Model Type: Fixed-Wing/Gliders/Helicopter RF Range: 2.408-2.475GHz RF Power: < 20dBm RF Channel: 135 Bandwidth: 500KHz 2.4GHz System: AFHDS 2A / AFDHS Modulation Type: GFSK Stick Resolution 4096 Low Voltage Warning: < 4.2V DSC port: PS/2 Port PPM Chargeable: No Antenna Length: 26mm (Dual Antenna)</p>

	<p>Weight: 392g</p> <p>Power: 6V DC 1.5AA*4</p> <p>Display: STNTransflective Display, LCD 128x64 Lattice, VA 73x39mm, LCD with white backlight</p> <p>Size: 174x89x190mm</p> <p>On-line Update: Yes</p> <p>Color: Black</p> <p>Certificate: CE0678, FCC ID: N4ZFLYSKYI6X</p>
<p>FS-A8S Receiver</p>	<p>Brand Name:Flysky</p> <p>Item Name:FS-A8S Receiver</p> <p>Channels: PPM 8CH, i-BUS 18CH</p> <p>Model type: Multi-rotor</p> <p>Frequency range: 2.408-2.475GHz</p> <p>Band width: 500KHz</p> <p>Band number: 135</p> <p>RX Sensitivity: -92 dBm</p> <p>2.4GHz system: AFHDS 2A</p> <p>Modulation type: GFSK</p> <p>DSC port: PPM/i-BUS/S.BUS</p> <p>Transfer method: FHSS</p> <p>Data output: 1.5mm*3 Pin PPM/i-BUS/S.BUS</p> <p>Antenna length: 26mm (Not including brass contacts)</p> <p>Input power supply: 4.0-8.4V</p> <p>Display method: LED</p> <p>No ground interference (Transmitting and receiving 1 m from the ground): > 300m</p> <p>Working current: 40mA</p> <p>Each channel data: depend on the transmitter</p> <p>Channel delay: <15mS</p> <p>Size: 20*14*5.3mm</p> <p>Weight: 1.2g</p>

	<p>Certificate: CE0678, FCCID: N45ZA8S00</p>
--	--

Compatible Transmitter: Compatible with FS-i4, FS-i6,
FS-i6S, FS-i6X, FS-i10, FS-GT2E, FS-GT2G, FS-GT2F