

FOR AGES 14+

MINI FOLDABLE ARM QUADCOPTER Instruction manual

**APPLICABLE MODEL: ALTITUDE
HOLD PRODUCTS**

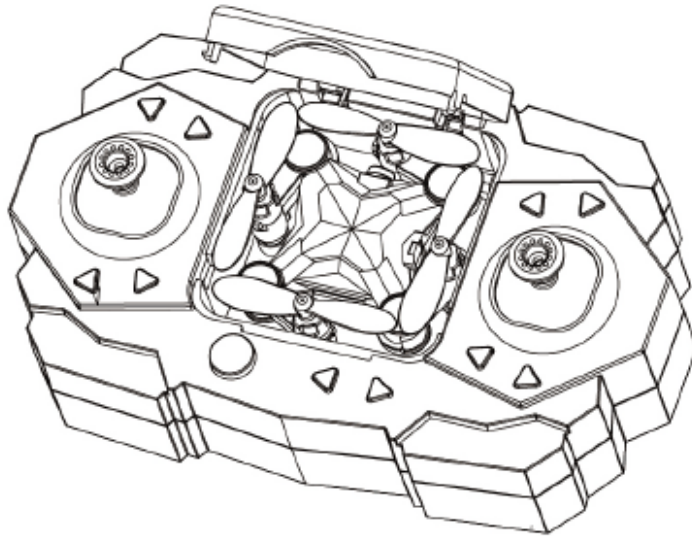

Thank you for your support of HELIWAY, Please read the user instructions carefully before usage.

Notice:

Our products used gyroscopes. It can fly in small space or outdoor, it can meet your desire for flying if the wind is less than level 3.

Aircraft uses 2.4Ghz which have a long-distance control and operate by several persons in the same time. It has some 4 CH function such as forward, backward, left and right sideward fly, turn left and right. It also can do some special action like 3D rolling.

In order to operate the aircraft easily, please read the manual carefully before using and retain the manual.

SAFTY&CAUTIONS

1. Please put the smaller parts of aircraft at place where children can't touch, avoid accidents.
2. The aircraft has powerful energy, at first flight, you should slowly push left lever. Avoid aircraft flies rapidly and result in collisions and damage.
3. After flight, turn off the remote control and the aircraft.
4. Do not put the battery in the high temperature, hot place. (such as: near the fire or electric heating device)
5. During flight, the aircraft should keep away from the user or others about 2-3 meters. Avoid injure others when the aircraft lands.
6. Do not let children play alone, children should play under the guidance of adults.
7. Non rechargeable batteries are not rechargeable, install batteries with correct polarity and do no mix different types of batteries.
8. When stop flying please turn off the power of transmitter and remove the batteries of aircraft and transmitter out.
9. The power supply terminal can not be short circuit.
10. Don't look the light directly because it has radiation.

TRANSMITTER & AIRCRAFT INTRODUCTION

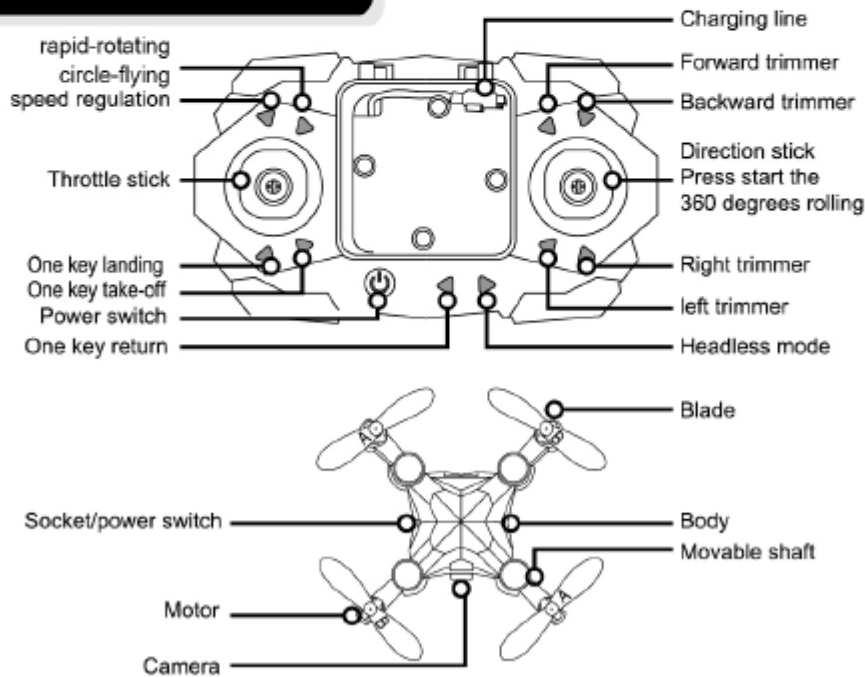

PS: Replace the blade according to the corresponding location of the propeller AB in the figure.

Installation and adjustment

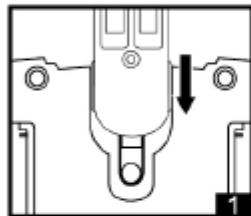
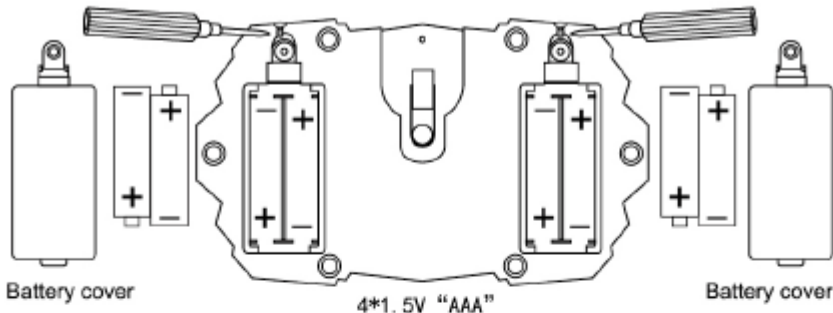

1. Take the telephone rack into a card slots which on the back of transmitter.

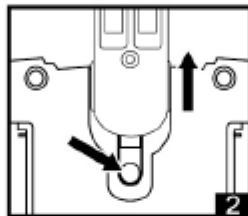

2. If you want to take out the telephone rack, you should hold the round button which on the back of transmitter (see chart), and up it.

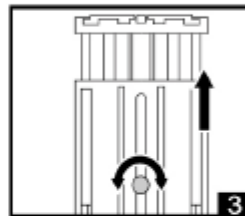

3. You can rotate the metal parts anticlockwise to pull up or shrink the telephone rack. Then rotate the metal parts clockwise to fixed it after you adjusted the width of the telephone rack.

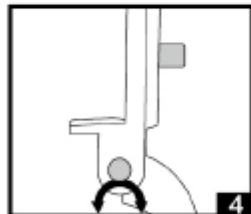

4. You can rotate the metal parts which on the side of telephone rack to adjust the angle of telephone rack, then rotate the metal parts clockwise to fixed it.

PS: Only later will 901HS distribution cell phone holder

Battery charging

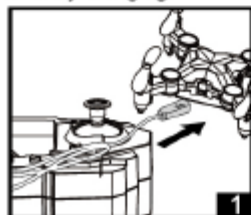

Turn off the aircraft then turn on the transmitter, and connect the charging cable with the interface of transmitter. The blue light is on when charging, red light is on when charging finishes. Charging time is about 40-60 minutes.

CAUTIONS

You should confirm the transmitter has enough power if you want to charge.

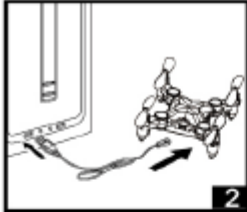

Turn off the aircraft, using the USB charging line to connect the charging plug of aircraft and the USB interface of computer.

The USB charging line lights when charging, the light goes out when charging finish.

Charging time is about 60 minutes.

Headless Mode

★ Start and setting: put the aircraft in a horizontal position or make it hovering in the air and confirm the front of aircraft (red LED light) with the transmitter in the same direction ahead. Pressing the button of headless mode (the transmitter "D1", the indicator light keep green), aircraft's diagonal LED light flash. It means open the headless mode.

★ Drop out the headless mode: Pressing the button of headless mode (the transmitter "D1", the indicator light go out), aircraft's LED light. It means drop out the headless mode.

★ You can switch to the headless mode at any time even in flying.

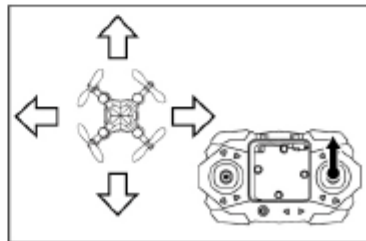
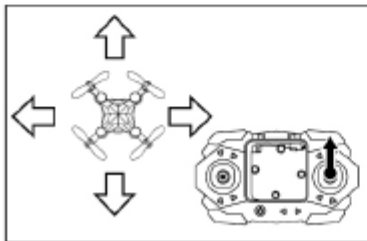
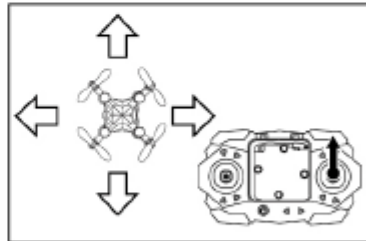
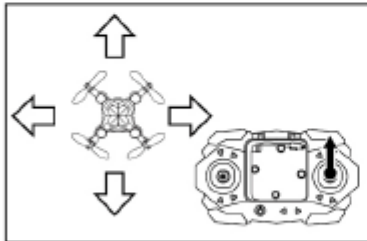
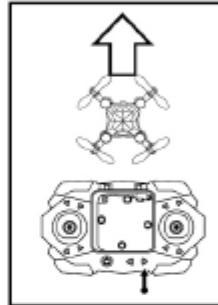

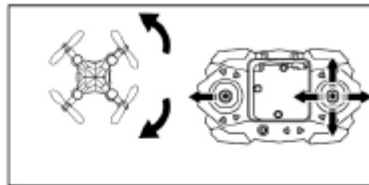
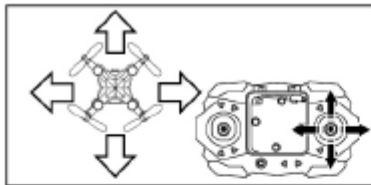

As shown in the above figure, in CF Mode (the bottom four LED lights keep flashing quickly) No matter where the aircraft locates(the red light is the onward direction), now the position of the remote controller is the rear of the aircraft. At this time, push the direction lever down, the aircraft will come back, and push the direction lever up, the aircraft will fly far away.

Emergency stop

- ★ push the left throttle stick to the lower right, and push the right throttle stick to the lower left. The aircraft stop flying.

Gyroscope calibration

- ★ When the aircraft suffers impact or external collision, aircraft's direction will be wrong. at this time, the aircraft should be landed on the flat ground, to ensure the front direction of the aircraft(the red light is the onward direction) is consistent with the transmitter's. Pushing the left lever right, and push the right lever left (This action should be carried out at the same time.)

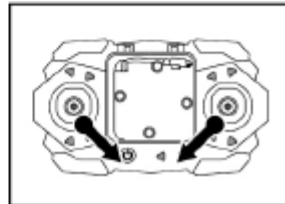

Unlock

- ★ Before starting the aircraft, turning the throttle sticks inwards to calibration. After finishing the calibration, turning the throttle sticks outwards to unlock. propellers of Aircraft turn at low speed, Pushing the throttle sticks, aircraft at a lower speed.

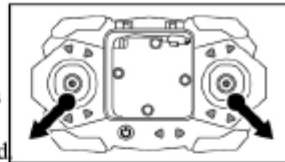

One key return

- ★ Press the button of one key return, (the transmitter "Di"), the aircraft will return automatically. You can push the right lever up to correct the channel if off course. Press the button of one key return again(the transmitter "Di"), the aircraft end return. Or push the right lever up to end return.

One key take-off/landing

- ★ One key take-off: After finish the unlock, push the one key take-off button the controller sends a "tick" sound, After finishing one key return, the aircraft hover about 1.5m height
- ★ One key landing: After the aircraft flies, push one key landing button, the controller sends a "tick" sound. After finishing one key landing, the aircraft slowly down to the ground, the aircraft stop turning.

WIFI FPV INSTRUCTION



APP (IOS)



Play (Android)

SCAN QR CODE FOR DOWNLOAD OUR WIFI APP

We advise the beginner should practice within 10 meters.
After you are skillful, you can control in far distance.

According to you mobile phone systems, scanning QR code and download the APP.
Open Settings. Find the unlocked WIFI of aircraft, and connect it.

Start the related app to enter startup layout, turn on height-locating mode and click "START"
to enter control interface. Video display means successful connection.

Note: only 901HS comes with this function.

Flying Preparation

1: Binding with the aircraft.
Clockwise rotate the four wings of aircraft in turn, stretch the aircraft to the flying condition.
(as pictured to the right)

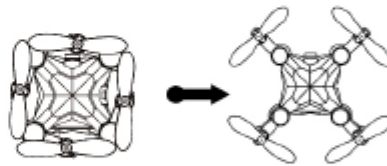





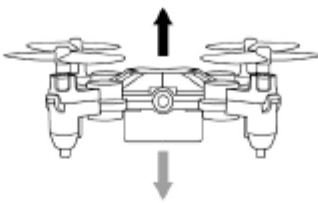
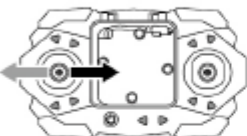
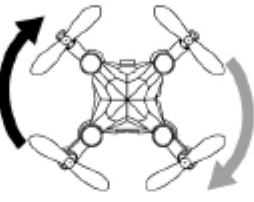
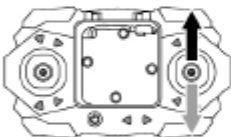
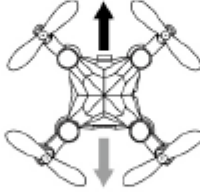
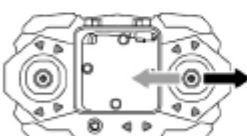
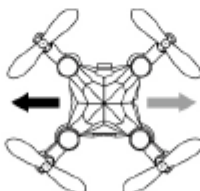

2. Syncing the aircraft.
Turning on the aircraft, keep it in a horizontal position.
Then turn on the transmitter, the bottom four LED lights flash quickly.
Push the throttle lever to the highest position, then pull it back to the lowest position,
there will be one clear sound from the transmitter, it shows the binding finishes

3. Calibration
Pushing the left lever right, and push the right lever left (This action should be carried out at the same time.) The bottom four LED lights flash quickly, then become bright all through, it means the calibration succeeds.
Note: Before flying, the aircraft need to be calibrated.

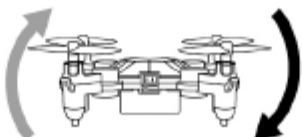
4. Low power alarm
When the aircraft is in the low battery state, the bottom four LED lights keep flashing slowly. The flight should be stopped. You need to charge the aircraft.

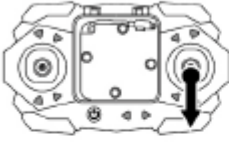
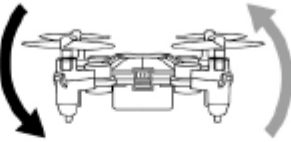
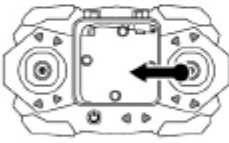
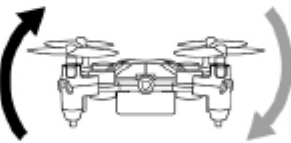
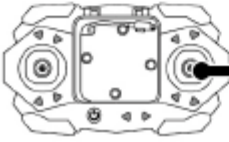
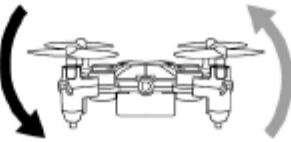
Instructions

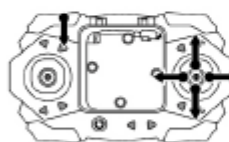
	 <p>Push the throttle lever up or down, the aircraft flies upward or downward.</p>
	 <p>Push the throttle lever left or right, the aircraft turns to left or right.</p>
	 <p>Push the direction lever up or down, the aircraft flies forward or backward.</p>
	 <p>Push the direction lever left or right, the aircraft flies to left side or right side.</p>
	 <p>Vertically hold the direction lever and push forward, the aircraft does 360° forward rolling action.</p>

	 <p>Vertically hold the direction lever and push backward, the aircraft does 360 ° backward rolling action.</p>
	 <p>Vertically hold the direction lever and push left, the aircraft does 360 ° rolling action on the left side.</p>
	 <p>Vertically hold the direction lever and push right, the aircraft does 360 ° rolling action on the right side.</p>
	 <p>Press this button for 1s, quadcopter starts to rotate rapidly as CW direction. Push direction stick freely to exit rapid-rotating status.</p>
	 <p>Press this button for 3s, quadcopter starts to fly as a CW circle. Push direction stick freely to exit circle-flying status.</p>

Protective cover installation instructions

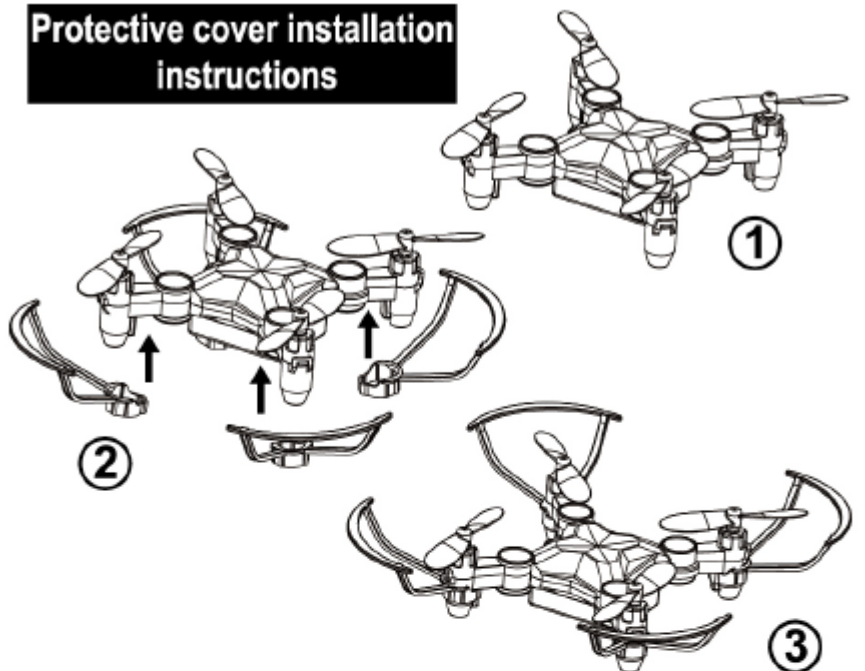

Attention

- Keep a suitable distance from the aircraft for safety.
- Do not look straightly to the lights, as the lights may generate laser radiation.
- If the transmitter or aircraft is lack of power, the control distance and height of flying will be affected.
- If the aircraft is broken, please repair it in time. Do not use aircraft with damaged propellers.
- Please put out the batteries to avoid battery leakage when do not be used for a long time.
- Do not let the aircraft crash at a high altitude, because the aircraft will be damaged and its lifetime will be shorter.

Special note

Push the the throttle lever slowly, You can use the button of trimmer to calibrate if the aircraft spinning or deviating in the sky.

Note: When the aircraft fly within 30 cm between the ground or the ceiling,
The aircraft becomes unstable because of blades swirl, this is "Ground effect".
Lower weight,bigger ground effect.

Notes of using the li-po battery

- The use of lithium-ion batteries has certain risk, it may cause personal injury, or property damage.
- The user should bear all the responsibility.
- The manufacturers and dealers can't control batteries (charge and discharge and storage, etc.).
- Also can't be responsible for any personal and property losses.

Charger and charge

- Use only factory supplied charger. Before cleaning the model, make sure the model is disconnected from the charger.
- Do not charge or use the swelling, leaking or damaged battery.
- Do not overcharge the battery. When the battery are fully charged, pull out the charge. After charge complete, do not recharge to avoid overheat.
- Do not charge near combustible or flammable (carpet, wood floor, solid wood furniture, etc.) or on surface of conductive objects. Should observe the battery at any time.
- Don't charge when the battery is still hot.
- The temperature of the battery is between 0°C and 40°C.
- Pull out the charger when not charged.

Use and store

- Do not use plastic packaging has been damaged batteries.
- When the product is turned on, do not insert or remove the battery.
- Do not allow the battery to excessive physical shock.
- Do not use the expansion, leakage, breakage, or emits an odor of the battery.
- Children contact with battery is prohibited.
- Do not put battery into the fire, to avoid contact with liquid, the model can not be exposed to the rain, and should not be placed in the damp place.
- Please do not remove the battery or cut, drill. The battery or charger can not carry heavy things. Do not knock the battery.
- Do not use solvents, alcohol, or other flammable solvents to clean the charger.
- Prevent the short circuit. Avoid direct contact with electrolytic material of the battery, electrolytic material and electrolytic steam is harmful to the body.
- Store products under greenhouse. Please do not put product in extreme temperatures.
- Avoid the temperature of storage has important changes.
- Please do not place the product in the heat source.

recycle

- Not handling the product as a daily garbage.
- The discarded battery should be placed in a special designated container.
- The products consists of electronic element and batteries.
- With regard to discarded electrical and electronic, please handle it according to the special requirements. Please be familiar with the local waste treatment.

FCC Warning:

This equipment has been tested and found to comply with the limits for a Class B digital device, pursuant to part 15 of the FCC Rules. These limits are designed to provide reasonable protection against harmful interference in a residential installation. This equipment generates, uses and can radiate radio frequency energy and, if not installed and used in accordance with the instructions, may cause harmful interference to radio communications. However, there is no guarantee that interference will not occur in a particular installation. If this equipment does cause harmful interference to radio or television reception, which can be determined by turning the equipment off and on, the user is encouraged to try to correct the interference by one or more of the following measures:

- Reorient or relocate the receiving antenna.
- Increase the separation between the equipment and receiver.
- Connect the equipment into an outlet on a circuit different from that to which the receiver is connected.
- Consult the dealer or an experienced radio/TV technician for help.

Caution: Any changes or modifications to this device not explicitly approved by manufacturer could void your authority to operate this equipment.

This device complies with part 15 of the FCC Rules. Operation is subject to the following two conditions: (1) This device may not cause harmful interference, and (2) this device must accept any interference received, including interference that may cause undesired operation.

The device complies with RF specifications when the device used at 10mm from your body.