

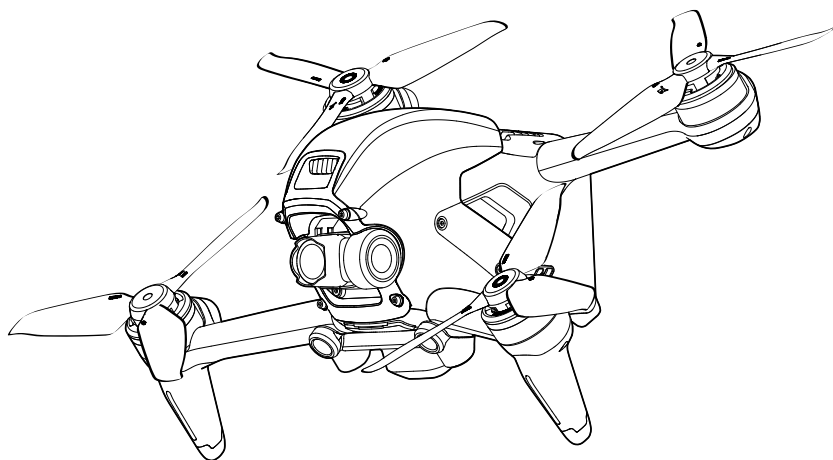

# User Manual

v1.2 2021.06



## **Searching for Keywords**

Search for keywords such as “battery” and “install” to find a topic. If you are using Adobe Acrobat Reader to read this document, press Ctrl+F on Windows or Command+F on Mac to begin a search.

## **Navigating to a Topic**

View a complete list of topics in the table of contents. Click on a topic to navigate to that section.

## **Printing this Document**

This document supports high resolution printing.

## **Revision Log**

Version	Date	Revisions
v1.2	2021.06	<ol style="list-style-type: none"><li>1. Added information for Intelligent Flight Battery maintenance. (P28)</li><li>2. Added information for goggles operation. (P32)</li><li>3. Modified information of some parameters and RTH when the aircraft is in a GEO zone. (P19, P61, P63)</li></ol>

---

# Using this Manual

## Legend



Warning



Important



Hints and Tips



Reference

## Read Before the First Flight

Read the following documents before using DJI™ FPV.

1. User Manual
2. Quick Start Guide
3. Disclaimer and Safety Guidelines

It is recommended to watch all tutorial videos on the official DJI website and read the disclaimer and safety guidelines before using for the first time. Prepare for your first flight by reviewing the quick start guide and refer to this user manual for more information.

## Video Tutorials

Visit the address below or scan the QR code to watch the DJI FPV tutorial videos, which demonstrate how to use DJI FPV safely:

<https://www.dji.com/dji-fpv/video>



## Download the DJI Fly App

Scan the QR code on the right to download DJI Fly.

The Android version of DJI Fly is compatible with Android v6.0 and later. The iOS version of DJI Fly is compatible with iOS v11.0 and later.



\* For increased safety, flight is restricted to a height of 98.4 ft (30 m) and a range of 164 ft (50 m) when not connected or logged into the app during flight. This applies to DJI Fly and all apps compatible with DJI aircraft.

## Download the DJI Virtual Flight App

Scan the QR code on the right to download DJI Virtual Flight.

The iOS version of DJI Virtual Flight is compatible with iOS v11.0 and later.



## Download DJI Assistant 2 (DJI FPV series)

Download DJI ASSISTANT™ 2 (DJI FPV Series) at <https://www.dji.com/dji-fpv/downloads>.



The operating temperature of this product is -10° to 40° C. It does not meet the standard operating temperature for military grade application (-55° to 125° C), which is required to endure greater environmental variability. Operate the product appropriately and only for applications that it meets the operating temperature range requirements of that grade.

# Contents

<b>Using this Manual</b>	<b>3</b>
Legend	3
Read Before the First Flight	3
Video Tutorials	3
Download the DJI Fly App	3
Download the DJI Virtual Flight App	3
Download DJI Assistant 2 (DJI FPV series)	3
<b>Product Profile</b>	<b>6</b>
Introduction	6
Preparing the Aircraft	7
Preparing the Goggles	8
Preparing the Remote Controller	10
Diagram	10
Linking	14
Activation	15
<b>Aircraft</b>	<b>16</b>
Flight Modes	16
Aircraft Status Indicator	17
Return to Home	18
Vision Systems and Infrared Sensing System	20
Flight Recorder	23
Propellers	23
Intelligent Flight Battery	25
Gimbal and Camera	29
<b>Goggles</b>	<b>31</b>
Power Supply	31
Operation	32
Home Screen	32
Menu Bar	34
<b>Remote Controller</b>	<b>39</b>
Operation	39
Optimal Transmission Zone	43
Stick Adjustment	44
<b>DJI Fly App</b>	<b>45</b>

<b>Flight</b>	<b>47</b>
Flight Environment Requirements	47
Flight Limits and GEO Zones	47
Pre-Flight Checklist	48
Starting/Stopping the Motors	49
Flight Test	50
<b>Maintenance</b>	<b>51</b>
Goggles	51
Aircraft	52
<b>Appendix</b>	<b>61</b>
Specifications	61
Calibrating the Compass	65
Updating Firmware	66
After-Sales Information	66

# Product Profile

## Introduction

DJI FPV consists of an aircraft, goggles, and remote controller, which all feature DJI's O3 technology that provides video transmission with a maximum transmission range of 6 mi (10 km), bit rate of up to 50 Mbps, and minimum end-to-end latency within 28 ms. DJI FPV works at both 2.4 and 5.8 GHz and is capable of selecting the best transmission channel automatically. The enhanced anti-interference ability greatly improves the smoothness and stability of the video transmission, providing an integrated and immersive flight experience.

Featuring a Forward and Downward Vision System and Infrared Sensing System, the aircraft can hover and fly indoors as well as outdoors and automatically initiate Return to Home (RTH). With a gimbal and 1/2.3" sensor camera, the aircraft stably shoots 4K 60fps ultra-HD video and 4K photos. The aircraft has a maximum flight speed of 87 mph (140 kph) and a maximum flight time of approximately 20 minutes.

The DJI FPV Goggles V2 are equipped with a high-performance display and support 810p 120fps HD display and real-time audio transmission. By receiving the video signal from the aircraft, users can enjoy a first-person view of their aerial experience in real time. The goggles have a maximum runtime of approximately 1 hour and 50 minutes when used with DJI FPV Goggles Battery and where the ambient temperature is 25° C and the screen brightness is set to 6.

The DJI FPV Remote Controller 2 is equipped with a range of function buttons, which can be used to control the aircraft and operate the camera. The maximum runtime of the remote controller is approximately 9 hours.

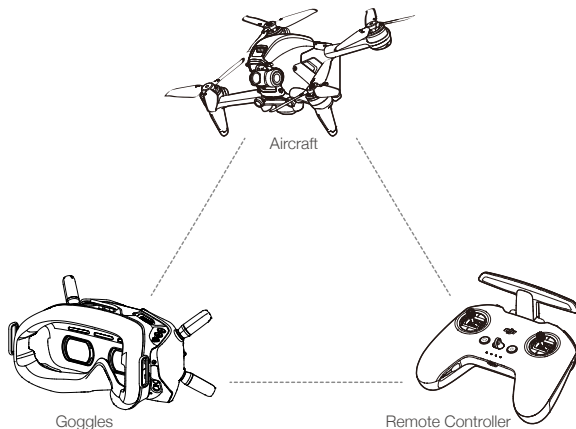

- The remote controller reaches its maximum transmission distance (FCC) in a wide-open area with no electromagnetic interference when the aircraft is at an altitude of approximately 400 ft (120 m). The maximum transmission distance refers to the maximum distance that the aircraft can still send and receive transmissions. It does not refer to the maximum distance the aircraft can fly in a single flight.
- The end-to-end latency is the total time from camera sensor input to screen display. The DJI FPV can reach its minimum latency in Low Latency mode (810p 120fps) in a wide open area with no electromagnetic interference.
- Maximum flight time was tested in an environment with no wind while flying at a consistent 24.9 mph (40 kph) and the maximum flight speed was tested in Manual mode at sea level altitude with no wind. These values are for reference only. The maximum flight speed of the aircraft varies depending on national and regional regulations.

- ⚠ 5.8 GHz is not supported in some regions. This frequency band will automatically be disabled when the aircraft is activated or connected to DJI Fly in these regions. Observe local laws and regulations.
- Using the goggles does not satisfy the requirement of visual line of sight (VLOS). Some countries or regions require a visual observer to assist by observing the flight. Make sure to comply with local regulations when using the goggles.

## Preparing the Aircraft

1. Remove the gimbal protector from the camera.

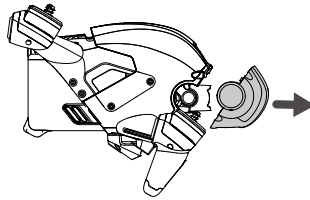

2. Attach the propellers.

Propellers with and without marks indicate different directions of rotation. Attach the propellers with marks to the motors with marks and the unmarked propellers to the motors without marks. Hold the motor, press the propeller down, and rotate in the direction marked on the propeller until it pops up and locks in place.

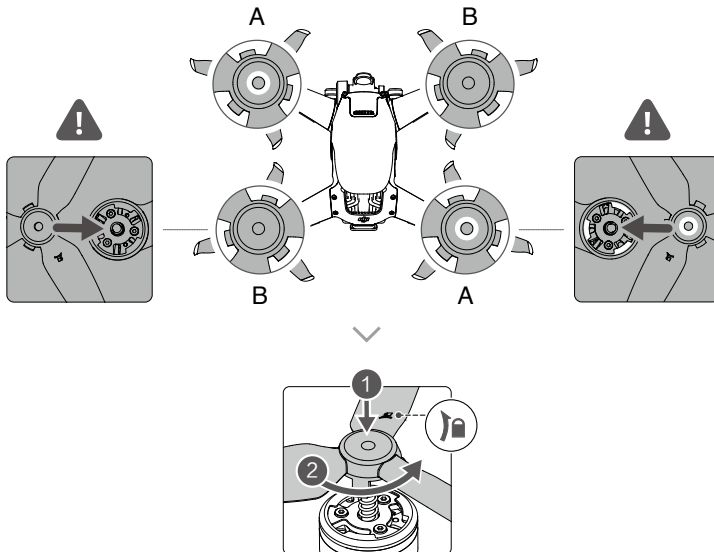

3. All Intelligent Flight Batteries are in hibernation mode before shipping to ensure safety. Remove the Intelligent Flight Battery and use the provided charger to charge and activate the Intelligent Flight Batteries for the first time. It takes approximately 50 minutes to fully charge an Intelligent Flight Battery.

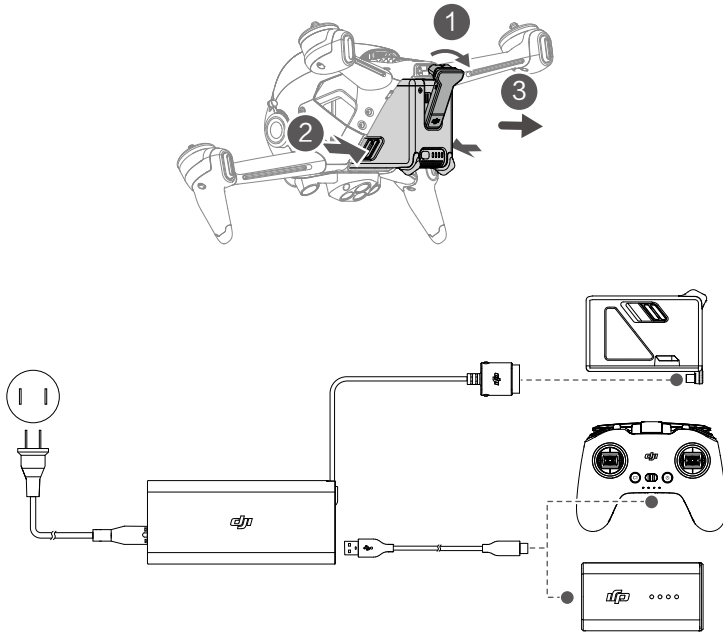

---

 It is recommended to attach a gimbal protector to protect the gimbal when the aircraft is not in use.

---

 Make sure the gimbal protector is removed before powering on the aircraft. Otherwise, it may affect the aircraft self-diagnostics.

---

## Preparing the Goggles

1. Install the four antennas to the mounting holes on the front of the goggles. Make sure that the antennas are installed securely.

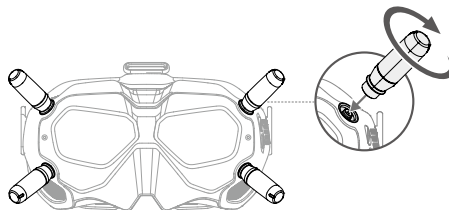



2. Attach the strap to the headband attachment on the top and sides of the goggles.

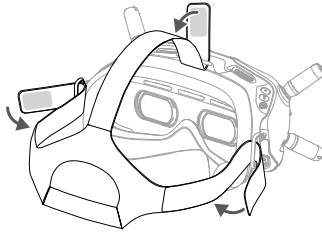

3. Use the included power cable to connect the power port of the goggles to the goggles battery.

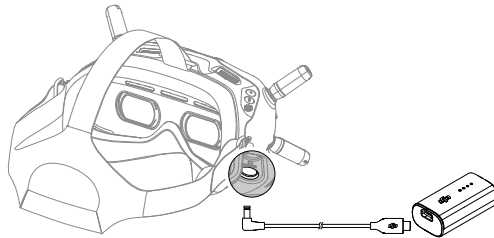

4. Align the lenses over your eyes and pull the headband down. Adjust the headband size until the goggles fit securely and comfortably on your face and head.

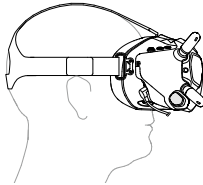

5. Turn the Interpupillary Distance (IPD) slider to adjust the distance between the lenses until the images are properly aligned.



58 – 70 mm

---

 The goggles can be worn over glasses.

---

 DO NOT use the goggles battery to power other mobile devices.

---

## Preparing the Remote Controller

1. Remove the control sticks from the storage slots on the remote controller and screw them into place.
2. Unfold the antennas.

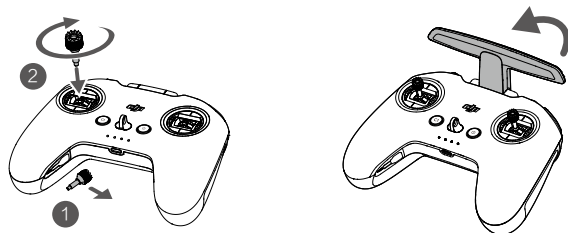

## Diagram

### Aircraft

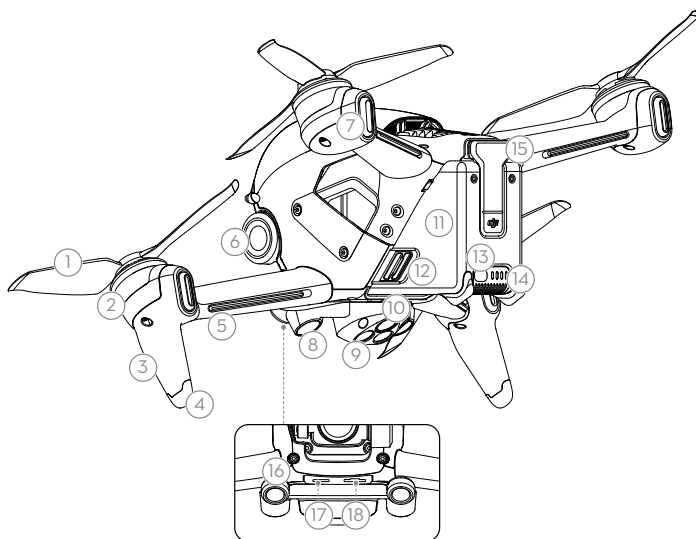

- |                                      |                                |                           |
|--------------------------------------|--------------------------------|---------------------------|
| 1. Propellers                        | 7. Aircraft Status Indicator   | 13. Power Button          |
| 2. Motors                            | 8. Downward Vision System      | 14. Battery Level LEDs    |
| 3. Front LED                         | 9. Infrared Sensing System     | 15. Power Port            |
| 4. Landing Gears (Built-in antennas) | 10. Auxiliary Bottom Light     | 16. Forward Vision System |
| 5. Frame Arms LED                    | 11. Intelligent Flight Battery | 17. USB-C Port            |
| 6. Gimbal and Camera                 | 12. Battery Buckles            | 18. microSD Card Slot     |

## Goggles

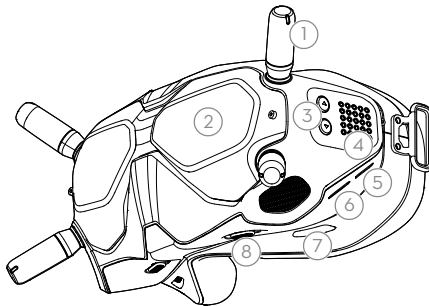

1. Antennas
2. Front Cover
3. Channel Adjustment Buttons
4. Channel Display
5. USB-C Port
6. microSD Card Slot
7. Air Intake
8. IPD Slider

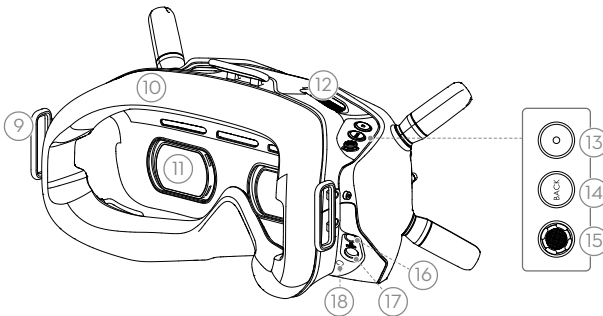

9. Headband Attachment

10. Foam Padding

11. Lens

12. Air Vent

13. Shutter/Record Button

Press once to take photos or start or stop recording. Press and hold to switch between photo and video mode.

14. Back Button

Press to return to the previous menu or exit the current mode.

15. 5D Button

Toggle the button to scroll through the menu. Press the button to confirm.

On the main screen, toggle left or right to adjust the screen brightness and toggle up or down to adjust the volume. Press the button to enter the menu.

16. Audio/AV-IN Port

17. Power Port (DC5.5×2.1)

18. Link Button

## Remote Controller

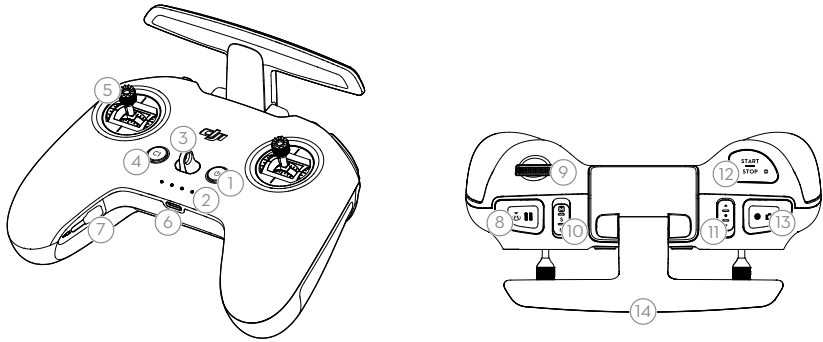

- 1. Power Button**  
Press once to check the current battery level. Press once, then again, and hold to power the remote controller on or off.
- 2. Battery Level LEDs**  
Displays the current battery level of the remote controller.
- 3. Lanyard Attachment**
- 4. C1 Button (Customizable)**  
The function of this button can be adjusted in the goggles. By default, press once to adjust or disable Coordinated Turn (S Mode). Press twice to enable or disable ESC Beeping.
- 5. Control Sticks**  
Used to control the movements of the aircraft. The control sticks mode can be set in the goggles. The control sticks are removable and easy to store.
- 6. USB-C Port**  
For charging and connecting the remote controller to the computer.
- 7. Control Sticks Storage Slot**  
For storing the control sticks.
- 8. Flight Pause/RTH Button**  
Press once to make the aircraft brake and hover in place (only when GPS or Downward Vision System are available). Press and hold the button to initiate RTH. The aircraft returns to the last recorded Home Point. Press again to cancel RTH.
- 9. Gimbal Dial**  
Controls the tilt of the camera.
- 10. Flight Mode Switch**  
Switch between Normal, Sport, and Manual mode. Manual mode is disabled by default and must be enabled in the goggles.
- 11. C2 Switch (Customizable)**  
The function of this switch can be adjusted in the goggles. By default, toggle the switch to recenter the gimbal and adjust up and down.

### 12. Start/Stop Button

When using Sport mode, press once to enable or disable cruise control.

When using Manual mode, press twice to start or stop the motor.

When using Normal or Sport mode, press once to cancel Low Battery RTH when the countdown appears in the goggles.

### 13. Shutter/Record Button

Press once to take photos or start or stop recording. Press and hold to switch between photo and video mode.

### 14. Antennas

Relays aircraft control wireless signals.

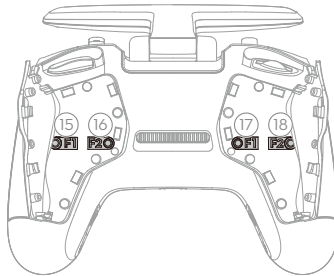

### 15. F1 Right Stick Resistance Adjustment Screw (Vertical)

Tighten the screw clockwise to increase the vertical resistance of the corresponding stick. Loosen the screw to decrease vertical resistance.

### 16. F2 Right Stick Recentering Adjustment Screw (Vertical)

Tighten the screw clockwise to disable the vertical recentering of the corresponding stick. Loosen the screw to enable vertical recentering.

### 17. F1 Left Stick Resistance Adjustment Screw (Vertical)

Tighten the screw clockwise to increase the vertical resistance of the corresponding stick. Loosen the screw to decrease vertical resistance.

### 18. F2 Left Stick Recentering Adjustment Screw (Vertical)

Tighten the screw clockwise to disable the vertical recentering of the corresponding stick. Loosen the screw to enable vertical recentering.

## Linking

The devices are all linked before shipping. Linking is only required when using a new device for the first time. Follow the steps below to link the aircraft, goggles, and remote controller:

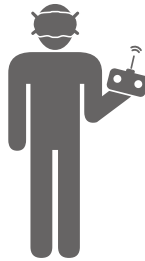

1. Power on the aircraft, goggles, and remote controller.
2. Press the link button on the goggles. The goggles will start to beep continually.
3. Press and hold the power button of the aircraft until the battery level LEDs start to blink in sequence.

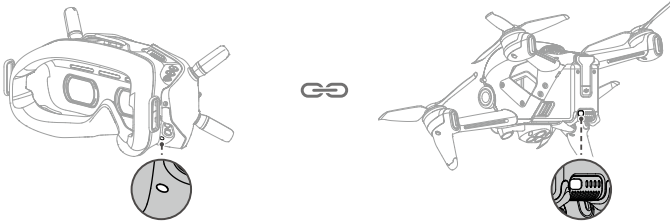

4. The battery level LEDs of the aircraft turn solid and display the battery level. The goggles stop beeping when they are successfully linked and the video display is normal.
5. Press and hold the power button of the aircraft until the battery level LEDs start to blink in sequence.
6. Press and hold the power button of the remote controller until it starts to beep continually and the battery level LEDs blinks in sequence.

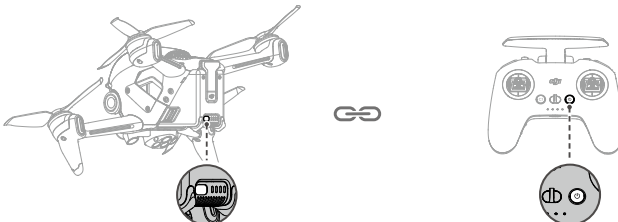

7. Once linking is successful, the remote controller stops beeping and both the battery level LEDs turn solid and display the battery level.

---

 Make sure the goggles and the remote controller are within 0.5 m of the aircraft during linking.

---

 The aircraft must be linked with the goggles before the remote controller.

---

## Activation

DJI FPV must be activated before using for the first time. Make sure all devices are linked after powering on the aircraft, goggles, and remote controller. Connect the USB-C port of the goggles to the mobile device, run DJI Fly, and follow the prompts to activate. An internet connection is required for activation.

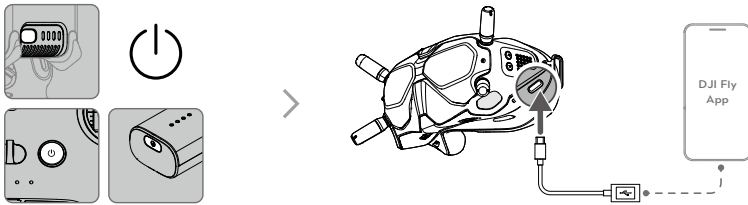

 Press and then press and hold to power devices on or off.

---

# Aircraft

DJI FPV contains a flight controller, a gimbal and camera, video downlink system, vision system, propulsion system, and an Intelligent Flight Battery.

## Flight Modes

DJI FPV has three flight modes, plus a fourth flight mode that the aircraft switches to in certain scenarios. Flight modes can be switched via the flight mode switch on the remote controller.

**Normal Mode:** The aircraft utilizes GPS, the Forward and Downward Vision Systems, and the Infrared Sensing System to locate itself and stabilize. The aircraft will use GPS to locate itself when the GPS signal is strong and use the Downward Vision System to locate and stabilize itself when the lighting conditions are sufficient. When the Downward Vision System is enabled and lighting conditions are sufficient, the maximum flight attitude angle is 25° and the maximum flight speed is 15 m/s.

**Sport Mode:** The aircraft uses GPS and the Downward Vision System for positioning. In Sport mode, aircraft responses are optimized for agility and speed making it more responsive to control stick movements. The maximum flight speed is 27 m/s, maximum ascent speed is 15 m/s, and maximum descent speed is 10 m/s.

**Manual Mode:** Classic FPV aircraft control mode with the highest maneuverability, which can be used for racing and freestyle flying. In Manual mode, all flight assistance functions such as automatic stabilization are disabled and proficient control skills are required. The throttle stick can be adjusted in this mode.

In Normal or Sport mode, when the Downward Vision System is unavailable or disabled and when the GPS signal is weak or the compass experiences interference, the aircraft cannot position itself or brake automatically, which increases the risk of potential flight hazards. At this time, the aircraft may be more easily affected by its surroundings. Environmental factors such as wind can result in horizontal shifting, which may present hazards, especially when flying in confined spaces.



- When using Manual mode, move the remote control stick to directly control the throttle and attitude of the aircraft. The aircraft has no flight assistance functions such as automatic stabilization and can reach any attitude. Only experienced pilots should use Manual mode. Failure to operate in this mode properly is a safety risk and may even lead to the aircraft crashing.
  - Manual mode is disabled by default. Make sure that the switch is set to Manual mode in the goggles before switching to Manual mode. The aircraft will remain in Normal or Sport mode if the switch is not set to Manual mode in the goggles. Go to Settings, Control, Remote Control, and then Button Customization and set the Custom Mode to Manual Mode.
  - Before using Manual mode, it is recommended to adjust the screw on the rear of the throttle stick so that the stick does not recenter and to practice flying in the mode using DJI Virtual Flight.
  - When using Manual mode for the first time, the maximum attitude of the aircraft will be limited. After you are familiar with flying in Manual mode, the attitude restriction can be disabled in the goggles. Go to Settings, Control, Remote Control, RC Exp, and then M Mode Attitude Limit.
  - The maximum speed and braking distance of the aircraft significantly increase in Sport mode. A minimum braking distance of 30 m is required in windless conditions.
  - Descent speed significantly increases in Sport mode. A minimum braking distance of 10 m is required in windless conditions.
  - The responsiveness of the aircraft significantly increases in Sport mode, which means a small control stick movement on the remote controller translates into the aircraft moving a large distance. Be vigilant and maintain adequate maneuvering space during flight.
-



## Aircraft Status Indicator

DJI FPV has a front LED, frame arm LED, and aircraft status indicator.

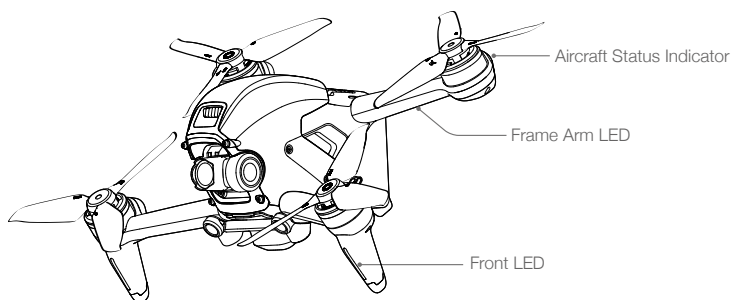

The front LED shows the orientation of the aircraft and the frame arm LED is for decoration. The LEDs turn solid blue when the aircraft is powered on. The colors and lighting methods of the front LED and frame arm LED can be customized in the goggles.



The aircraft status indicator shows the status of the flight control system of the aircraft. Refer to the table below for more information about the aircraft status indicator.

### Aircraft Status Indicator States

Normal States		
	Blinks red, yellow, and green alternately	Powered on and performing self-diagnostic tests
	Blinks purple slowly	Warming up
	Blinks green slowly	GPS enabled
	Blinks green twice repeatedly	Forward and Downward Vision Systems enabled
	Blinks yellow slowly	GPS and Forward and Downward Vision System disabled
	Blinks green quickly	Braking
Warning States		
	Blinks yellow quickly	Remote controller signal lost
	Blinks red slowly	Low battery
	Blinks red quickly	Critically low battery
	Blinks red	IMU error
	Solid red	Critical error
	Blinks red and yellow alternately	Compass calibration required

## Return to Home

The Return to Home (RTH) function brings the aircraft back to the last recorded Home Point and lands when the GPS signal is strong. There are three types of RTH: Smart RTH, Low Battery RTH, and Failsafe RTH. If the aircraft successfully recorded the Home Point and the GPS signal is strong, the RTH will be triggered when either Smart RTH is initiated, the aircraft battery level is low, or the signal between the remote controller and the aircraft is lost. RTH will also be triggered in other abnormal scenarios such as if there is a loss of video transmission.

	GPS	Description
Home Point		The default Home Point is the first location where the aircraft received a strong or moderately strong GPS signal (where the icon shows white). The aircraft status indicator blinks green quickly and a prompt appears in the goggles to confirm the Home Point has been recorded.

### Smart RTH

If the GPS signal is sufficient, Smart RTH can be used to bring the aircraft back to the Home Point. Smart RTH is initiated by pressing and holding the RTH button on the remote controller. Exit Smart RTH by pressing the RTH button.

### Low Battery RTH

When the Intelligent Flight Battery level is too low and there is not enough power to return home, land the aircraft as soon as possible. Otherwise, the aircraft will fall when it runs out of power, resulting in the aircraft being damaged and other potential hazards.

To avoid unnecessary danger due to insufficient power, DJI FPV will intelligently determine whether the current battery level is sufficient to return to the Home Point based on the current location. Low Battery RTH is triggered when the Intelligent Flight Battery is depleted to the point that the safe return of the aircraft may be affected.

RTH can be cancelled by pressing the RTH button on the remote controller. If RTH is cancelled following a low battery level warning, the Intelligent Flight Battery may not have enough power for the aircraft to land safely, which may lead to the aircraft crashing or being lost.

The aircraft will land automatically if the current battery level can only support the aircraft long enough to descend from its current altitude. Auto landing cannot be canceled, but the remote controller can be used to alter the direction of the aircraft during the landing process.



Manual mode does not support Low Battery RTH. If a prompt appears on the goggles that the battery only has enough power to return to the home point, the user must fly the aircraft to the home point manually.

### Failsafe RTH

If the Home Point was successfully recorded and the compass is functioning normally, Failsafe RTH automatically activates after the remote controller signal is lost for more than 3.5 seconds.

The aircraft will fly backwards for 50 m on its original flight route and enter Straight Line RTH. The aircraft enters Straight Line RTH if the remote controller signal is restored during Failsafe RTH.

The response of the aircraft when the wireless signal is lost can be changed in the goggles. The aircraft will not execute Failsafe RTH if land or hover has been selected in the settings.

### Other RTH Scenarios

A prompt will appear in the goggles and RTH will be initiated if the video download signal is lost during flight while

the remote controller can still be used to control the movements of the aircraft.

### RTH (Straight Line)

1. The Home Point is recorded.
2. RTH is triggered.
3. If the aircraft is less than 5 m from the Home Point when RTH begins, it lands immediately.

If the aircraft is more than 5 m and less than 50 m from the Home Point when RTH begins, it will return home at the current altitude with a maximum horizontal speed of 3 m/s.

If the aircraft is further than 50 m from the Home Point when RTH begins, it will ascend to the RTH altitude and return home at a speed of 13.5 m/s. The aircraft flies to the Home Point at the current altitude if the RTH altitude is lower than the current altitude.

4. After reaching the Home Point, the aircraft lands and the motors stop.

### Obstacle Avoidance During RTH

1. The aircraft brakes when an obstacle is sensed from in front and ascends to a safe distance. After ascending another 5 m, the aircraft will continue to fly forward.
2. The aircraft brakes when an obstacle is sensed from below and ascends until obstacles are no longer sensed before flying forward.



- During RTH, the aircraft cannot sense obstacles to the side, rear, or from above.
  - The aircraft cannot avoid obstacles during RTH if the Forward and Downward Vision Systems are unavailable.
  - The aircraft cannot return to the Home Point if the GPS signal is weak or unavailable. If the GPS signal becomes weak or unavailable after RTH is triggered, the aircraft will hover in place for a while before landing.
  - Before each flight, it is important to enter Settings and then Safety on the goggles and set a suitable RTH altitude.
  - During RTH, if the aircraft is flying forward and the remote controller signal is normal, the remote controller can be used to control the speed of the aircraft, but cannot control the orientation or fly left or right. The orientation and horizontal position of the aircraft can be controlled when it is descending. When the aircraft is ascending or flying forward, push the control stick completely in the opposite direction to exit RTH.
  - GEO zones will affect RTH. The aircraft will hover in place if it flies into a GEO zone during RTH.
  - The aircraft may not be able to return to a Home Point when the wind speed is too high. Fly with caution.
- 

### Landing Protection

Landing Protection will activate during Smart RTH.

1. During Landing Protection, the aircraft will automatically detect and carefully land on suitable ground.
2. If the ground is determined unsuitable for landing, the aircraft will hover and wait for pilot confirmation.
3. If Landing Protection is not operational, the goggles will display a landing prompt when the aircraft descends to 0.3 m. Pull down on the throttle stick to land.



Vision Systems are disabled during landing. Make sure to land the aircraft with caution.

---

## Precision Landing

The aircraft automatically scans and attempts to match the terrain features below during RTH. The aircraft will land when the terrain matches the terrain of the Home Point. A prompt will appear in the goggles if the terrain fails to match.



- Landing Protection is activated during Precision Landing.
- The performance of Precision Landing is subject to the following:
  - a) The Home Point must be recorded upon takeoff and must not be changed during flight. Otherwise, the aircraft will have no record of the terrain features of the Home Point.
  - b) During takeoff, the aircraft must ascend vertically to at least 7 m before moving horizontally.
  - c) The terrain features of the Home Point must remain largely unchanged after it is recorded.
  - d) The terrain features of the Home Point must be sufficiently distinctive.
  - e) The lighting conditions must not be too light or dark.
- The following actions are available during Precision Landing:
  - a) Pull the throttle stick down to accelerate landing.
  - b) Pull the throttle stick up or move the other control stick to stop Precision Landing. Landing Protection remains active while the aircraft descends vertically.

## Vision Systems and Infrared Sensing System

DJI FPV aircraft is equipped with both an Infrared Sensing System and Forward and Downward Vision Systems.

The Forward and Downward Vision Systems consist of two cameras each and the Infrared Sensing System consists of two 3D infrared modules.

The Downward Vision System and Infrared Sensing System help the aircraft maintain its current position, hover in place more precisely, and to fly indoors or in other environments where GPS is unavailable. In addition, the auxiliary bottom light located on the underside of the aircraft improves visibility for the Downward Vision System in weak light conditions.

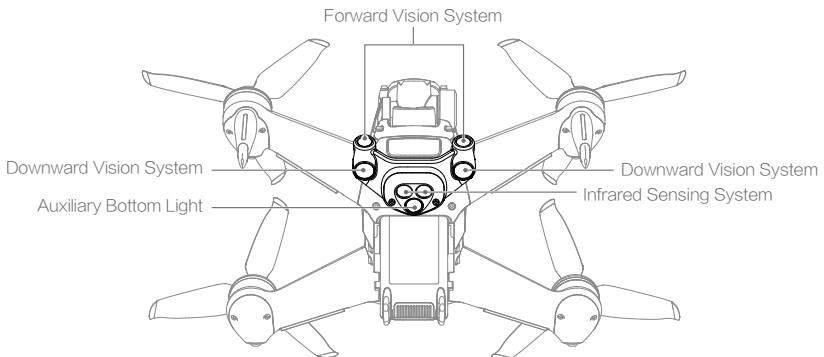

## Detection Range

### Forward Vision System

The Forward Vision System has a detection range of 0.5 to 18 m, horizontal FOV of 56°, and vertical FOV of 71°.

### Downward Vision System

The Downward Vision System works best when the aircraft is at an altitude of 0.5 to 15 m and its operating range is 0.5 to 30 m. The FOV to the front and rear is 106° and 90° to the right and left.

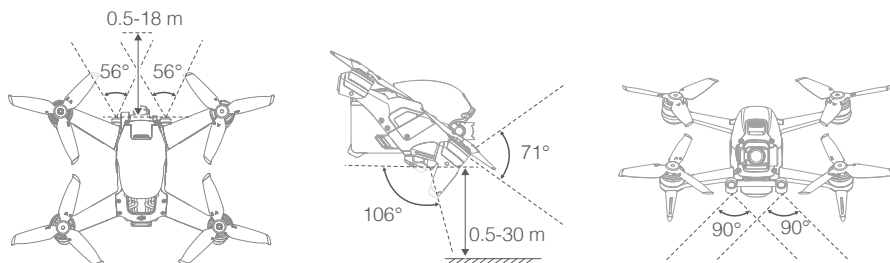

## Calibrating Vision System Cameras

### Auto Calibration

The Vision System cameras installed on the aircraft are calibrated before shipping. If any abnormality is detected with a Vision System camera, the aircraft will automatically calibrate and a prompt will appear in the goggles. No further action is required to address the issue.

### Advanced Calibration

If the abnormality persists after auto calibration, a prompt appears in the goggles that advanced calibration is required. Advanced calibration can only be performed using DJI Assistant 2 (DJI FPV series). Follow the steps below to calibrate the Forward Vision System cameras and repeat the steps to calibrate the other Vision System cameras.

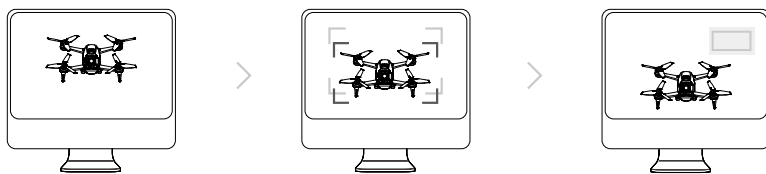

1

Point the aircraft toward the screen.

2

Align the boxes.

3

Pan and tilt the aircraft.

## Using the Vision Systems

The Downward Vision System is available if the surface has a clear texture and there is sufficient light. The Downward Vision System works best when the aircraft is at an altitude of 0.5 to 15 m. If the altitude of the aircraft is above 15 m, the Vision System may be affected. Extra caution is required.

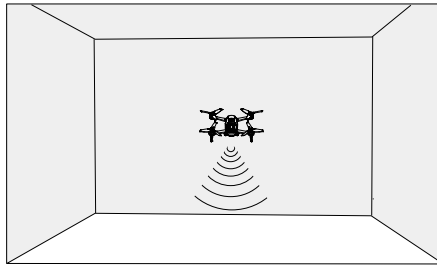

### Follow the steps below to use the Downward Vision System.

1. Make sure the aircraft is in Normal mode. Power on the aircraft.
2. The aircraft hovers in place after takeoff. The aircraft status indicator on the rear frame arm blinks green twice to indicate the Downward Vision System is working.

If the aircraft is in Normal mode and Obstacle Slowing is enabled in the goggles, the Forward Vision System will activate automatically when the aircraft is powered on. The Forward Vision System enables the aircraft to actively slow down when an obstacle is detected. The Forward Vision System works best with adequate lighting and clearly marked or textured obstacles. Due to inertia, users need to control the aircraft to brake within a reasonable distance.



- Pay attention to the flight environment. The Forward and Downward Vision Systems and Infrared Sensing System only work in certain scenarios and cannot replace human control and judgment. During flight, pay attention to the surrounding environment and to the warnings on the goggles. Be responsible for and maintain control of the aircraft at all times.
- The aircraft has a max hovering altitude of 30 m when using the Vision System in an open and flat environment. The best positioning altitude range of the Vision System is 0.5 to 15 m. The vision positioning performance may decrease when flying beyond this range. Fly with caution.
- The Auxiliary Bottom Light can be set on the goggles to on, off, or auto. In Auto, the auxiliary bottom light is automatically enabled when there is insufficient ambient light. The vision positioning performance will be negatively affected during this time. Be careful when flying if the GPS signal is weak.
- The Downward Vision System may not function properly when the aircraft is flying over water. Therefore, the aircraft may not be able to actively avoid water below when landing. It is recommended to maintain flight control at all times, make reasonable judgments based on the surrounding environment, and avoid relying on the Downward Vision System.
- Note that the Forward and Downward Vision Systems and Infrared Sensing System may not function properly when the aircraft is flying too fast.
- The Downward Vision System cannot work properly over surfaces that do not have clear pattern variations or there is weak light. The Downward Vision System cannot work properly in any of the following situations. Operate the aircraft cautiously.
  - a) Flying over monochrome surfaces (e.g., pure black, pure white, pure green).
  - b) Flying over highly reflective surfaces.
  - c) Flying over water or transparent surfaces.
  - d) Flying over moving surfaces or objects.

- ⚠ e) Flying in an area where the lighting changes frequently or drastically.
- f) Flying over extremely dark (< 10 lux) or bright (> 40,000 lux) surfaces.
- g) Flying over surfaces that strongly reflect or absorb infrared waves (e.g., mirrors).
- h) Flying over surfaces without clear patterns or texture. (e.g., power poles).
- i) Flying over surfaces with repetitive identical patterns or textures (e.g., tiles with the same design).
- j) Flying over obstacles with small surface areas (e.g., tree branches).
- Keep the sensors clean at all times. DO NOT tamper with the sensors. DO NOT use the aircraft in environments with significant dust or humidity. DO NOT obstruct the Infrared Sensing System.
- The camera must be calibrated if the aircraft is involved in a collision. Calibrate the cameras if prompted to do so in the goggles.
- DO NOT fly when it is rainy, foggy, or if there is no clear sight.
- Check the following every time before takeoff:
  - a) Make sure there are no stickers or any other obstructions over the Infrared Sensing System or Vision Systems.
  - b) If there is any dirt, dust, or water on the Infrared Sensing System or Vision Systems, clean with a soft cloth. DO NOT use any cleanser that contains alcohol.
  - c) Contact DJI Support if there is any damage to the glass of the Infrared Sensing System or Vision Systems.

## Flight Recorder

Flight data including flight telemetry, aircraft status information, and other parameters are automatically saved to the internal data recorder of the aircraft. The data can be accessed using DJI Assistant 2 (DJI FPV series).

## Propellers

There are two types of DJI FPV Quick-Release Propellers, which are designed to spin in different directions. Marks are used to indicate which propellers should be attached to which motors. Make sure to match the propeller and motor following the instructions.

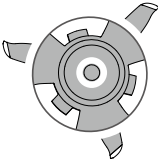
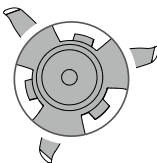
Propellers	With Marks	Without Marks
Illustration		
Mounting Position	Attach on motors with marks	Attach on motors without marks

## Attaching the Propellers

Attach the propellers with marks to the motors with marks and the unmarked propellers to the motors without marks. Hold the motor, press the propeller down, and rotate in the direction marked on the propeller until it pops up and locks in place.

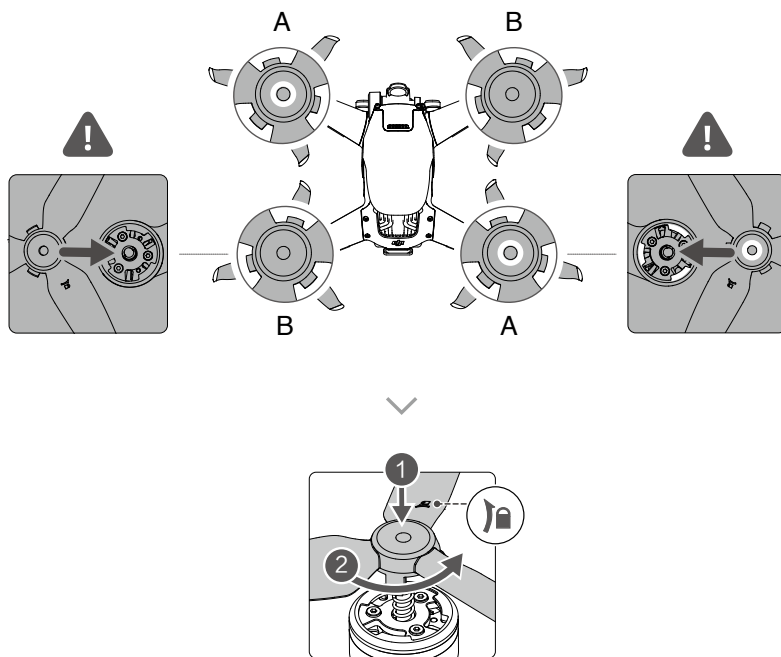

## Detaching the Propellers

Hold the motor, press the propeller down, and rotate in the opposite direction to the one marked on the propeller until it pops out.



- Propeller blades are sharp. Handle with care.
- Only use official DJI propellers. DO NOT mix propeller types.
- Purchase the propellers separately if necessary.
- Make sure that the propellers are properly attached before each flight.
- Make sure all propellers are in good condition before each flight. DO NOT use aged, chipped, or broken propellers.
- Stay away from the rotating propellers and motors to avoid injuries.
- Detach the propellers when storing. DO NOT squeeze or bend the propellers during transportation or storage.
- Make sure the motors are mounted securely and rotating smoothly. Land the aircraft immediately if a motor is stuck and unable to rotate freely.
- DO NOT attempt to modify the structure of the motors.
- DO NOT touch or let your hands or body come in contact with the motors after flight as they may be hot.
- DO NOT block any of the ventilation holes on the motors or the body of the aircraft.
- Make sure the ESCs sound normal when powered on.



## Intelligent Flight Battery

The FPV Intelligent Flight Battery is a 22.2 V, 2000 mAh battery with smart charging and discharging functionality.

### Battery Features

1. **Battery Level Display:** the battery level LEDs display the current battery level.
2. **Auto-Discharging Function:** to prevent swelling, the battery automatically discharges to approximately 97% of the battery level when it is idle for one day, and automatically discharges to approximately 60% of the battery level when it is idle for five days. It is normal to feel moderate heat being emitted from the battery while it is discharging.
3. **Balanced Charging:** the voltages of the battery cells are automatically balanced during charging.
4. **Overcharge Protection:** the battery stops charging automatically once fully charged.
5. **Temperature Detection:** to prevent damage, the battery only charges when the temperature is between 41° and 104° F (5° and 40° C). Charging stops automatically if the temperature of the battery exceeds 122° F (50° C) during charging.
6. **Overcurrent Protection:** the battery stops charging if an excess current is detected.
7. **Over-discharge Protection:** discharging stops automatically to prevent excess discharge when the battery is not in flight use. Over-discharge protection is not enabled when the battery is in flight use.
8. **Short Circuit Protection:** the power supply is automatically cut if a short circuit is detected.
9. **Battery Cell Damage Protection:** the goggles display a warning prompt when a damaged battery cell is detected.
10. **Hibernation Mode:** the battery switches off after 20 minutes of inactivity to save power. If the battery level is less than 10%, the battery enters Hibernation mode to prevent over-discharge after being idle for six hours. In Hibernation mode, the battery level indicators do not illuminate. Charge the battery to wake it from hibernation.
11. **Communication:** information about the voltage, capacity, and current of the battery is transmitted to the aircraft.

---

 Refer to the DJI FPV Disclaimer and Safety Guidelines and the stickers on the battery before use. Users accept full responsibility for any violations of the safety requirements stated on the label.

---



## Using the Battery



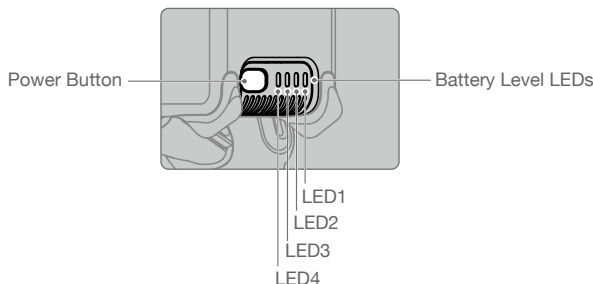





























### Checking Battery Level

Press the power button once to check the battery level.



 The battery level LEDs display the power level of the flight battery during charging and discharging. The statuses of the LEDs are defined below:

 LED is on.       LED is flashing.       LED is off.

LED1	LED2	LED3	LED4	Battery Level
				Battery Level > 88%
				75% < Battery Level ≤ 88%
				63% < Battery Level ≤ 75%
				50% < Battery Level ≤ 63%
				38% < Battery Level ≤ 50%
				25% < Battery Level ≤ 38%
				13% < Battery Level ≤ 25%
				0% < Battery Level ≤ 13%

## Powering On/Off

Press the power button once and then press again and hold for two seconds to power the battery on or off. The battery level LEDs display the battery level when the aircraft is powered on.

## Low Temperature Notice

1. Battery capacity is significantly reduced when flying in low-temperature environments of 14° to 41° F (-10° to 5° C). It is recommended to hover the aircraft in place for a while to heat the battery. Make sure to fully charge the battery before takeoff.
2. Batteries cannot be used in extremely low-temperature environments lower than 14° F (-10° C).
3. When in low-temperature environments, end the flight as soon as the goggles display the low battery voltage warning.
4. To ensure optimal performance, keep the battery temperature above 68° F (20° C).
5. The reduced battery capacity in low-temperature environments reduces the wind speed resistance performance of the aircraft. Fly with caution.
6. Exercise extra caution when flying high above sea level.

 In cold environments, insert the battery into the battery compartment and power on the aircraft to warm up before taking off.

## Charging the Battery

Use the provided DJI charger to fully charge the Intelligent Flight Battery before every flight.

1. Connect the AC power adapter to an AC power supply (100-240 V, 50/60 Hz).
2. Attach the Intelligent Flight Battery to the AC power adapter using the battery charging cable with the battery powered off.

- The battery level LEDs display the current battery level during charging.
- The Intelligent Flight Battery is fully charged when all the battery level LEDs are off. Detach the charger when the battery is fully charged.

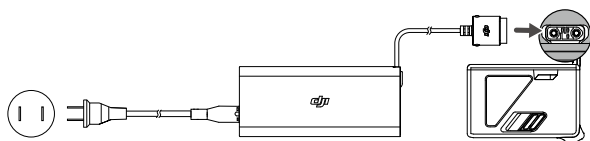

- The charging time is approximately 50 minutes.
- It is recommended to discharge the Intelligent Flight Batteries to 30% or lower. This can be done by flying the aircraft outdoors until there is less than 30% charge left.

- **DO NOT** charge an Intelligent Flight Battery immediately after flight as the temperature may be too high. Wait until it cools down to room temperature before charging again.
- The charger stops charging the battery if the battery cell temperature is not within the operating range of 41° to 104° F (5° to 40° C). The ideal charging temperature is 71.6° to 82.4° F (22° to 28° C).
- The Battery Charging Hub (not included) can charge up to three batteries. Visit the official DJI online store for more information about the Battery Charging Hub.
- Fully charge the battery at least once every three months to maintain battery health.
- DJI does not take any responsibility for damage caused by third-party chargers.

The table below shows the battery level during charging.

LED1	LED2	LED3	LED4	Battery Level
				0% < Battery Level ≤ 50%
				50% < Battery Level ≤ 75%
				75% < Battery Level < 100%
				Fully Charged

## Battery Protection Mechanisms

The battery level LEDs can display battery protection notifications triggered by abnormal charging conditions.

Battery Protection Mechanisms					
LED1	LED2	LED3	LED4	Blinking Pattern	Status
				LED2 blinks twice per second	Overcurrent detected
				LED2 blinks three times per second	Internal communication abnormal
				LED3 blinks twice per second	Overcharge detected
				LED3 blinks three times per second	Over-voltage charger detected
				LED4 blinks twice per second	Charging temperature is too low
				LED4 blinks three times per second	Charging temperature is too high

If any of the battery protection mechanisms are activated, unplug the charger, and plug it in again to resume charging. If the charging temperature is abnormal, wait for the charging temperature to return to normal and the battery will automatically resume charging without the need to unplug and plug the charger again.

### Installing/Removing the Battery

Install the Intelligent Flight Battery in the aircraft before use. Insert the Intelligent Flight Battery into the battery compartment of the aircraft. Make sure it is mounted securely and that the battery buckles are clicked into place before connecting it to the power port.

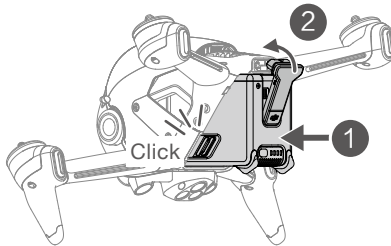

Disconnect the power port, press the battery buckles on the sides of the Intelligent Flight Battery, and remove it from the compartment.

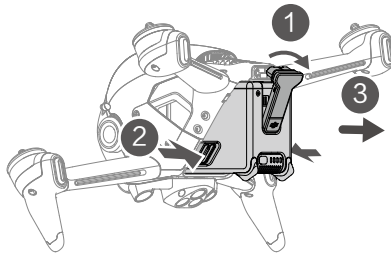

- 
-  • DO NOT detach the battery when the aircraft is powering on.
- Make sure that the battery is mounted firmly.
- 

### Maintenance

Return to home or land promptly if a prompt appears in the goggles that the Intelligent Flight Battery requires maintenance.

1. Fully charge the battery.
2. Leave the battery for 24 hours.
3. Insert the battery in the aircraft and hover at an altitude of up to 2 m after takeoff. When the battery reaches 20%, land the aircraft and power off and remove the battery.
4. Leave the battery for 6 hours.
5. Maintenance should now be complete and the battery is ready to use. Repeat the steps above if the maintenance prompt continues to appear in the goggles.

## Gimbal and Camera

### Gimbal Profile

The gimbal of DJI FPV aircraft stabilizes the camera and users can capture clear and stable images and videos even when the aircraft is flying at high speeds thanks to DJI's RockSteady electronic stabilization. The control tilt range is  $-50^{\circ}$  to  $+58^{\circ}$ . Use the gimbal dial on the remote controller to control the tilt of the camera.

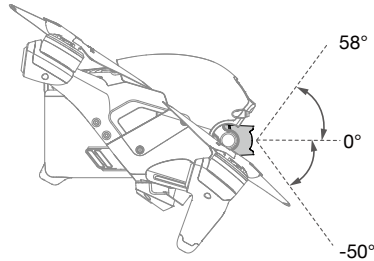

### Gimbal Mode

The gimbal mode will automatically switch according to the flight mode.

Normal/Sport mode: the gimbal is in attitude stabilization mode. The tilt angle of the gimbal remains stable relative to the horizontal plane, which is suitable for shooting stable images.

Manual mode: the gimbal is in FPV mode. The tilt angle of the gimbal remains stable relative to the aircraft body, which is suitable for FPV flight experience.



- When the aircraft is powered on, do not tap or knock the gimbal. Take off from open and flat ground to protect the gimbal during takeoff.
  - Precision elements in the gimbal may be damaged in a collision or impact, which may cause the gimbal to function abnormally.
  - Avoid getting dust or sand on the gimbal, especially in the gimbal motors.
  - A gimbal motor error may occur if the aircraft is on uneven ground, the gimbal is obstructed, or if the gimbal experiences excessive external force such as in a collision.
  - DO NOT apply external force to the gimbal after the gimbal is powered on. DO NOT add any extra payload to the gimbal as this may cause the gimbal to function abnormally or even lead to permanent motor damage.
  - Make sure to remove the gimbal protector before powering on the aircraft. Also, make sure to mount the gimbal protector when the aircraft is not in use.
  - Flying in heavy fog or clouds may make the gimbal wet, leading to temporary failure. The gimbal recovers full functionality once it is dry.
- 

### Camera Profile

DJI FPV uses a 1/2.3" CMOS sensor camera with a resolution of up to 12 million effective pixels. The aperture of the lens is F2.8, the focus range is 0.6 m to infinity, and the FOV of the lens can reach  $150^{\circ}$ .

DJI FPV camera can shoot up to 4K 60fps HD video and 4K photos.



- 4K video can only be recorded when the transmission quality is set to high quality.
  - Make sure the temperature and humidity are suitable for the camera during usage and storage.
  - Use a lens cleanser to clean the lens to avoid damage.
  - DO NOT block any ventilation holes on the camera as the heat generated may damage the device and injure the user.
- 

### Storing Photos and Videos

DJI FPV supports the use of a microSD card to store photos and videos. A UHS-I Speed Grade 3 rating or above microSD card is required due to the fast read and write speeds necessary for high-resolution video data. Refer to the Specifications for more information about recommended microSD cards.

---



- DO NOT remove the microSD card or the Intelligent Flight Battery from the aircraft while it is powered on. Otherwise, the microSD card may be damaged.
  - To ensure the stability of the camera system, single video recordings are limited to 30 minutes, after which recording will automatically stop.
  - Check camera settings before use to make sure the configurations are correct.
  - Before shooting important photos or videos, shoot a few images to test the camera is operating correctly.
  - Photos or videos cannot be transferred from the microSD card in the aircraft using DJI Fly if the aircraft is powered off.
  - Make sure to power off the aircraft correctly. Otherwise, the camera parameters will not be saved and any recorded videos may be affected. DJI is not responsible for any failure of an image or video to be recorded or having been recorded in a way that is not machine-readable.
-

# Goggles

The DJI FPV Goggles V2 give users a first-person view of the aerial camera with real-time video and audio transmission. They can also be used to play videos recorded by the goggles and set transmission, control, and camera parameters.

- ☀️ The DJI FPV Goggles V2 can also be used with the DJI FPV Air Unit. For more information, refer to the DJI Digital FPV System User Manual at <https://www.dji.com/fpv/info#downloads>. The DJI FPV Goggles V2 are not compatible with the DJI FPV Air Unit in regions that do not support 5.8 GHz. Observe local laws and regulations.

## Power Supply

Use the included goggles power cable (USB-C) to connect the power port of the goggles to the goggles battery.

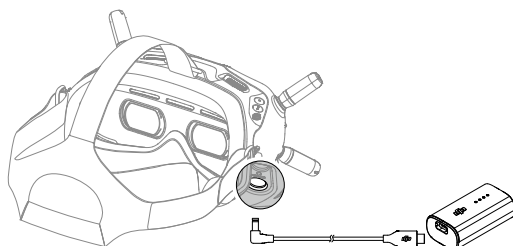

Press the power button once to check the current battery level.

Press once then press again and hold to power the goggles on or off.

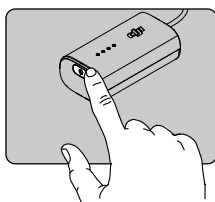

Charge the goggles battery if the battery level is low. It takes approximately 2 hours and 30 minutes to fully charge the battery.



- ☀️ If you need other batteries, prepare an external power supply with an input voltage of 11.1-25.2 V. The DJI FPV Goggles Power Cable (XT60) (not included) can be used with an external power supply to power the goggles. Visit the official DJI online store for more information about the DJI FPV Goggles Power Cable (XT60).

## Operation



### 5D Button

Toggle the button to scroll through the menu. Press the button to confirm.

On the home screen, press the button to enter the menu. Toggle left or right to adjust the screen brightness. Toggle up or down to adjust the volume.



### Shutter/Record Button

Press once to take photos or start or stop recording. Press and hold to switch between photo and video mode.



### Back Button

Press to return to the previous menu or exit the current mode.

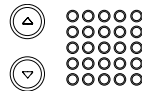

### Channel Adjustment Buttons

Press the up or down button to switch channels (only available when in manual channel mode).

### Channel Display

Displays the current channel of the goggles (will display A when in auto channel mode).

## Home Screen



### 1. Obstacle Detection Status

Indicates the distance between the aircraft and obstacles as well as the general direction of the obstacles. Red, orange, and gray bars indicate the relative distance ranging from near to far. Red bars are displayed when obstacles are close to the aircraft and orange bars are displayed when obstacles are within the detection range. Gray bars indicate there are no obstacles within the detection range.



### 2. microSD Card Information

Displays whether or not a microSD card is inserted in the aircraft or goggles as well as the remaining capacity. A flashing icon will appear when recording.

### 3. Gimbal Slider

Displays the gimbal tilt angle when the gimbal dial is toggled.

### 4. Prompts

Displays information such as when switching modes, when the battery level is low, and other warnings.

### 5. Goggles Battery Level

Displays the battery level of the goggles. The goggles will beep when the battery level is too low. The voltage will also be displayed if a third-party battery is being used.

### 6. GPS Status

Displays the current strength of the GPS signal.

### 7. Remote Controller and Video Downlink Signal Strength

Displays the remote controller signal strength between the aircraft and remote controller and the video downlink signal strength between the aircraft and the goggles.

### 8. Forward Vision System Status

Displays the status of the Forward Vision System. The icon is white when the Forward Vision System is working normally. Red indicates that the Forward Vision System is not enabled or working abnormally and the aircraft cannot automatically slow down when encountering obstacles.

### 9. Remaining Flight Time

Displays the remaining flight time of the aircraft after starting the motors.

### 10. Aircraft Battery Level

Displays the current battery level of the Intelligent Flight Battery on the aircraft.

### 11. Distance to the Ground

Displays the current altitude information of the aircraft from the ground when the aircraft is less than 10 m above the ground.

### 12. Flight Telemetry

D 1000 m, H 100 m, 9 m/s, 6 m/s: displays the distance between the aircraft and the Home Point, height from the Home Point, aircraft horizontal speed, and aircraft vertical speed.

### 13. Flight Modes

Displays the current flight mode.

### 14. Home Point

Indicates the location of the Home Point.



- The goggles will display the screen saver if they are not used for an extended period or disconnected from the aircraft. Press any button of the goggles or relink them to the aircraft to restore the video transmission display.

- If the devices are not used for an extended period, it may take longer than usual to search for the GPS signal. If the signal is unobstructed, it takes approximately 20 seconds to search for the GPS signal when powering on and off within a short period.



- If you select to record with both the aircraft and the goggles, the microSD card information of both the aircraft and goggles will be displayed on the home screen. If you select to record with only the aircraft or goggles, only the microSD card information of the corresponding device will be displayed.

---

## Menu Bar

Press the 5D button on the goggles to enter the menu bar.

### Status

Displays detailed information for current status warning prompts. Calibration is required if there are any IMU or compass abnormalities.

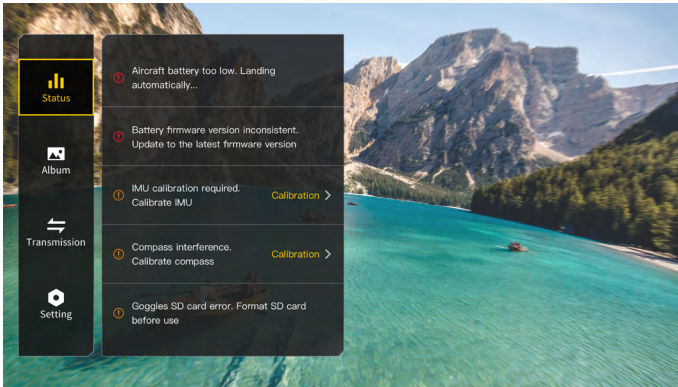

### Album

Shows the photos or videos stored on the microSD of the goggles. Select the file and confirm to preview.

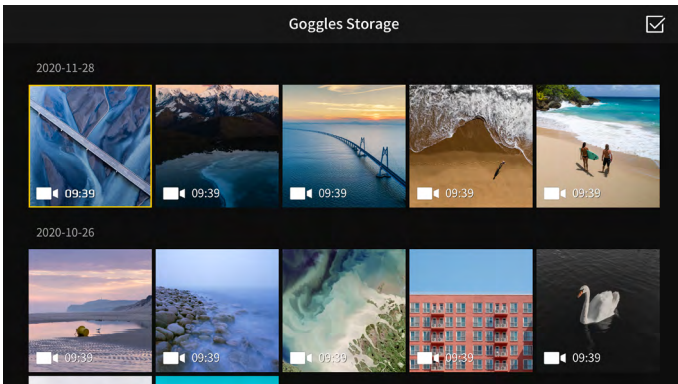

- Photos and videos recorded by the aircraft can be previewed. Insert the microSD card of the aircraft into the microSD card slot of the goggles.
- During video playback, press the 5D button to pause or continue, toggle the 5D button left or right to adjust the progress bar, and toggle up or down to adjust the volume.

## Transmission

The video transmission of the current device can be set under Pilot settings. Nearby video transmission devices and their signal strength can be viewed in Audience mode. Select a channel to see the camera view.



### 1. Broadcast Mode

Enable or disable Broadcast mode. The device number will be displayed when Broadcast mode is enabled so that other devices can find the device and enter the channel to watch the camera view.

### 2. Aspect Ratio

The aspect ratio of the video transmission screen can be adjusted.

### 3. Focus Mode

Set the Focus mode to on, off, or auto. If Focus mode is turned on, the center of the screen will be clearer and the edges will be blurred.

### 4. Channel Mode

The channel mode can be set to auto or manual. It is recommended to select auto so that the video transmission will intelligently switch between the 2.4 and 5.8 GHz frequency bands and select the channel with the best signal.

### 5. Frequency

You can select 2.4 or 5.8 GHz frequency band if the channel mode is manual.

### 6. Bandwidth

Set the bandwidth of the video transmission. The number of channels available varies according to the bandwidth. The channel with the best signal strength can be manually selected.

The larger the bandwidth, the more spectrum resources it occupies, which can provide a higher video transmission rate and clearer image quality. However, there is a higher chance of wireless interference and the amount of equipment that can be accommodated is more limited. To avoid interference in a multiplayer competition, it is recommended to manually select a fixed bandwidth and channel.

## Setting

### Safety

Set the safety configurations such as max flight altitude, max flight distance, and RTH altitude. Users can also update the Home Point, enable or disable Obstacle Slowing, and view the status of as well as calibrate the IMU and compass.

Find My Drone helps to find the location of the aircraft on the ground by using the cached video in the goggles.

Advanced Safety Settings include aircraft signal lost action, auxiliary bottom LED Status, and enabling or disabling AirSense and emergency propeller stop. The aircraft can be set to hover, land, or RTH when it loses the signal from the remote controller. If the emergency propeller stop is enabled, the motors can only be stopped by performing a combination stick command (CSC) mid-flight in an emergency situation such as if a collision occurs, a motor stalls, the aircraft rolls in the air, or the aircraft is out of control and is ascending or descending quickly. Stopping the motors mid-flight will cause the aircraft to crash.

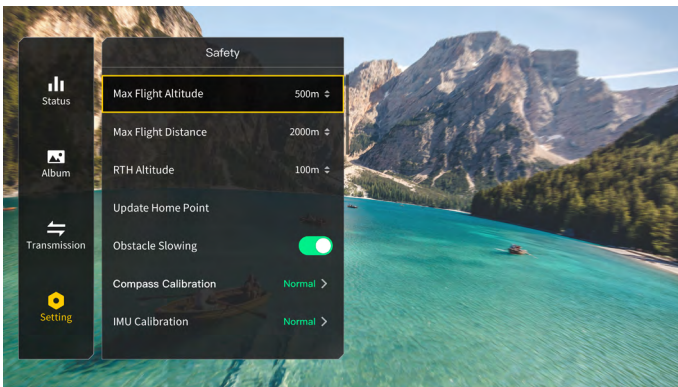

### Control

Set aircraft control parameters such as the color and lighting method of the front and frame arm LEDs, the gimbal pitch speed, or the Coordinated Turn (Sport mode). Users can also calibrate the gimbal.

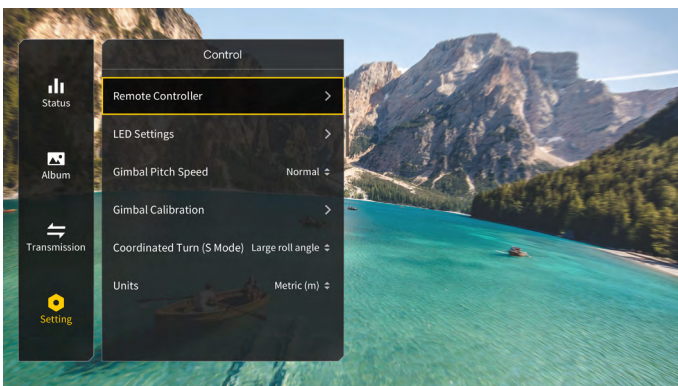

The functions of some of the buttons of the remote controller can be customized in Remote Controller. These include the C1 button, C2 switch, and the custom mode on the flight mode switch. The stick mode can be set and the exponential can be adjusted when using Manual mode. Users can also calibrate the remote controller.

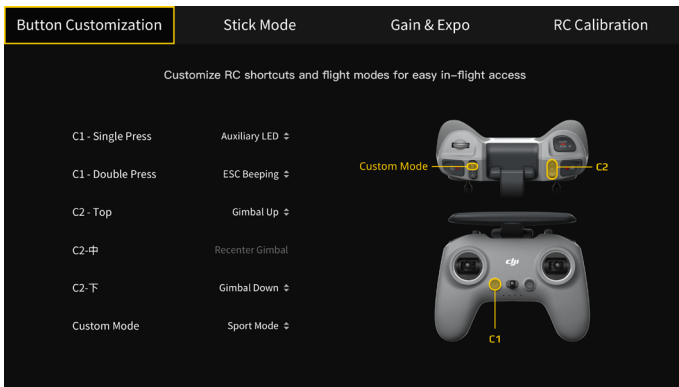

## Camera

Camera parameters such as ISO, shutter, EV, saturation, and WB can be adjusted. Also, the camera mode can be set to auto or manual. Shutter and ISO can be set in manual mode while EV can be set in auto mode.

Users can set transmission quality, video quality, video format, gridlines, enable or disable the center point of the screen, and format the microSD card. Note that the data cannot be recovered after formatting. Operate with caution.

In Advanced Camera Settings, users can set the recording device, video coding format, color, and anti-flicker, as well as enable or disable aircraft audio recording, video subtitles, distortion correction, image roll correction, and EIS (electronic image stabilization).

Select Reset Camera Parameters settings to restore all camera settings to default.

 When the frame rate of the video quality is 50/60fps, the audio and video will be stored together in one file. When the frame rate of the video quality is 100/120fps, the audio will be stored separately as an audio file and the video will be four times slower than normal while the audio will be normal.

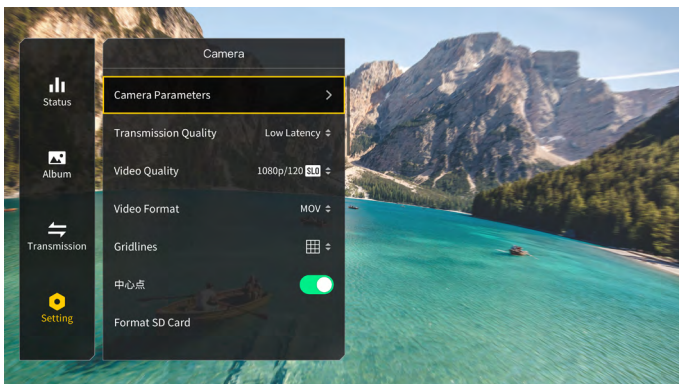

## Display

Adjust screen brightness, zoom, and display or hide the Home Point.

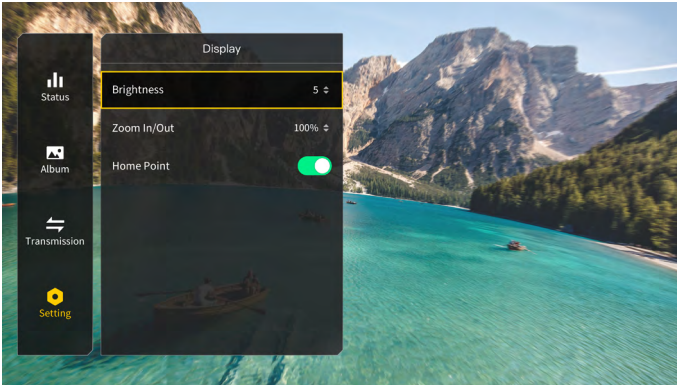

## About

View device information such as the serial number and the firmware of the goggles and the linked devices.

Switch to DJI FPV Digital System in the menu to use the DJI FPV Air Unit. Power on the goggles again after switching.

Select Reset All to reset the goggles and the linked devices to their default settings.

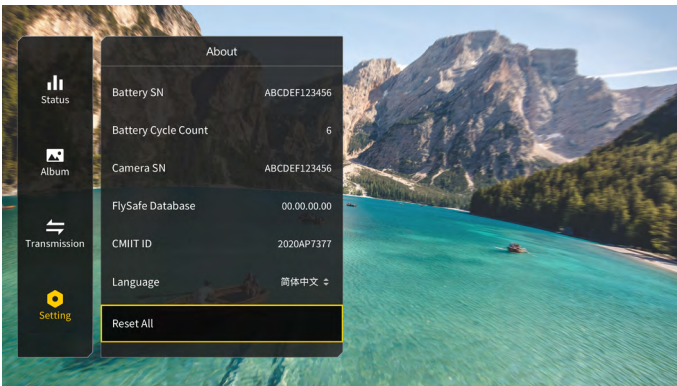

# Remote Controller

Built into the DJI FPV Remote Controller 2 is DJI's O3 transmission technology, offering a maximum transmission range of 6 mi (10 km). The buttons make control of the aircraft and camera effortless while the detachable control sticks allow for the remote controller to be easily stored.

The built-in battery has a capacity of 5200 mAh and a maximum run time of 9 hours.

## Operation

### Powering On/Off

Press the power button once to check the current battery level. If the battery level is too low, recharge before use.

Press once then press again and hold to power the remote controller on or off.

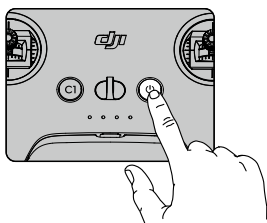

### Charging the Battery

Use a USB-C cable to connect an AC power adapter to the USB-C port of the remote controller. It takes approximately 2.5 hours to fully charge the remote controller.

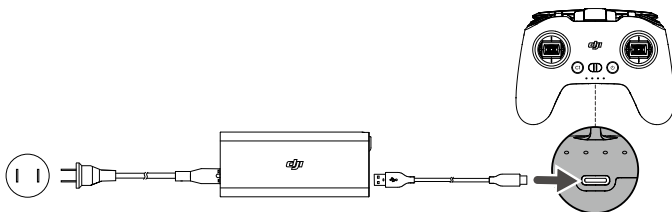

### Controlling the Gimbal and Camera

1. Shutter/Record Button: press once to take a photo or to start or stop recording. Press and hold to switch between photo and video mode.
2. Gimbal Dial: use to control the tilt of the gimbal.

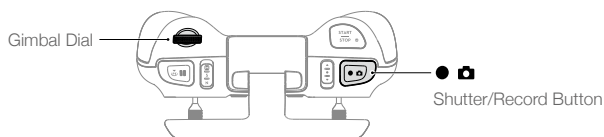

## Controlling the Aircraft

The control sticks control the orientation (pan), forward and backward movement (pitch), altitude (throttle), and left and right movement (roll) of the aircraft. The control stick mode determines the function of each control stick movement.



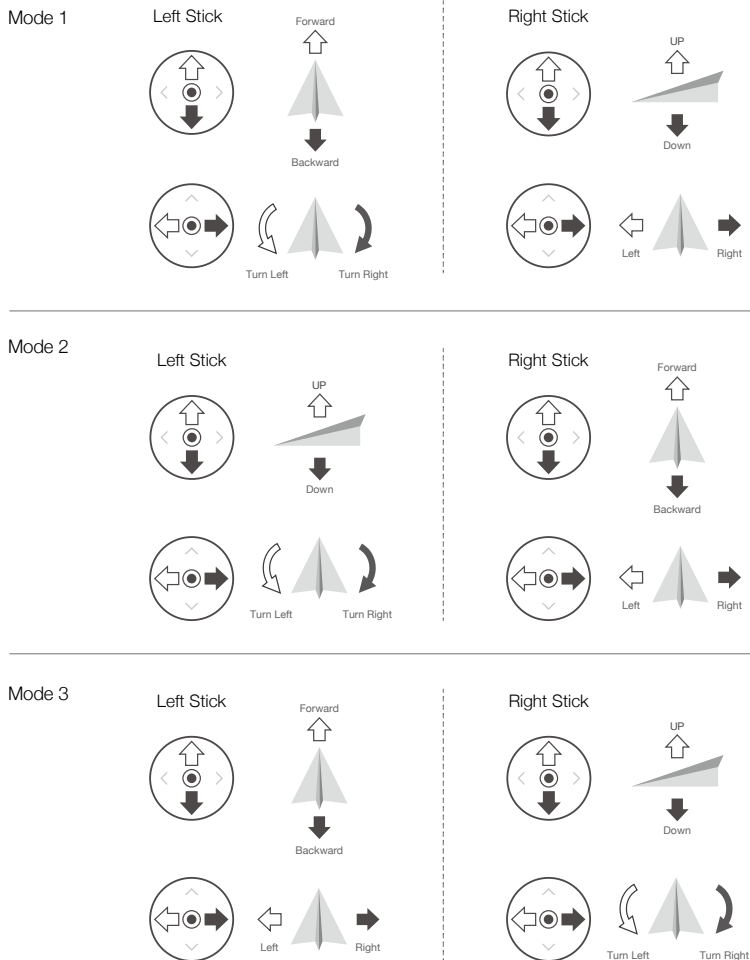



There are three programmed modes including Mode 1, Mode 2, and Mode 3. Mode 2 is selected by default and users can change to Mode 1 or Mode 3 in the goggles setting menu.

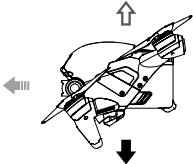

The figure below uses Mode 2 as an example to explain how to use the control sticks.

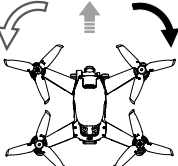
- Stick Neutral/Center Point: Control sticks are in the center.
- Moving the control stick: Push the control stick away from the center or push the throttle stick away from the lowest position when using Manual mode.

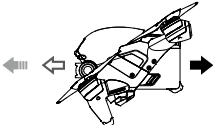

Remote Controller (Mode 2)	Aircraft (← Indicates nose direction)	Remarks
		<p>Throttle Stick: moving the left stick up or down changes the altitude of the aircraft.</p> <p>Push the stick up to ascend and down to descend. Push the stick gently to prevent sudden and unexpected changes in altitude.</p> <p><b>Normal/Sport mode:</b></p> <p>The aircraft hovers in place if the stick is in the center. Use the left stick to take off when the motors are spinning at an idle speed. The further the stick is pushed away from the center, the faster the aircraft changes elevation.</p> <p><b>Manual mode:</b></p> <p>The throttle stick has no center. Before flying, adjust the throttle stick to prevent it from returning to the center.</p>
		<p>Yaw Stick: moving the left stick to the left or right to control the orientation of the aircraft.</p> <p>Push the stick left to rotate the aircraft counterclockwise and right to rotate the aircraft clockwise. The aircraft hovers in place if the stick is in the center.</p> <p>The farther the stick is pushed away from the center, the faster the aircraft will rotate.</p>
		<p>Pitch Stick: moving the right stick up and down changes the pitch of the aircraft.</p> <p>Push the stick up to fly forward and down to fly backward. The aircraft hovers in place if the stick is in the center.</p> <p>The farther the stick is pushed away from the center, the faster the aircraft will move.</p>
		<p>Roll Stick: moving the right stick to the left or right changes the roll of the aircraft.</p> <p>Push the stick left to fly left and right to fly right. The aircraft hovers in place if the stick is in the center.</p> <p>The farther the stick is pushed away from the center, the faster the aircraft will move.</p>

### Flight Mode Switch

Toggle the switch to select the desired flight mode.

Position	Flight Mode
M	Manual Mode
S	Sport Mode
N	Normal Mode

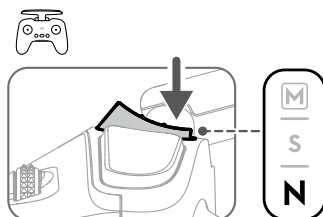

Manual mode is disabled by default. Make sure that the switch is set to Manual mode in the goggles before switching to Manual mode. The aircraft will remain in Normal or Sport mode if the switch is not set to Manual mode in the goggles. Go to Settings, Control, Remote Controller, Button Customization, and set the Custom Mode to Manual mode.

Before using Manual mode, it is recommended to tighten the F2 screw on the rear of the throttle stick so that the stick does not return to the center and adjust the F1 screw to make sure the stick resistance is suitable.

---

- ⚠ • When using Manual mode, the aircraft has no flight assistance functions such as automatic stabilization. Before using Manual mode, practice flying in Manual mode using DJI Virtual Flight to ensure that you can fly safely.
  - Only adjust the throttle stick before the aircraft takes off. DO NOT adjust during flight.
- 

### Start/Stop Button

When using Sport mode, press once to enable or disable cruise control. When cruise control is enabled, the aircraft will maintain the current flight speed and fly forward.

When using Manual mode, press twice to start or stop the motor.

When using Normal or Sport mode, press once to cancel Low Battery RTH when the countdown appears in the goggles.

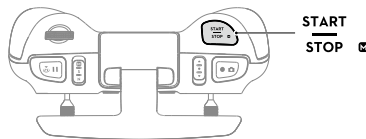

- ⚠ • Cruise control is only available in Sport mode.
  - When cruise control is enabled, the aircraft will maintain the current flight speed in the horizontal forward direction. The horizontal speed displayed on the goggles will change accordingly if the control sticks are moved or if the aircraft is flying in a windy environment.
- 

### Flight Pause/RTH Button

Press once to make the aircraft brake and hover in place. Make sure that the pitch stick and roll stick return to the center and push the throttle stick to resume control of the flight. If the aircraft is performing RTH or auto landing, press once to exit RTH before braking.

When the aircraft is in Manual mode, press the button to make the aircraft brake and hover in place. The aircraft attitude returns to level and the flight mode automatically switches to Normal mode.

Press and hold the RTH button until the remote controller beeps to indicate that RTH has started. Press the button again to cancel RTH and regain control of the aircraft. Refer to the Return to Home section for more information about RTH.



## Customizable Button

The functions of the customizable buttons can be set on the remote controller settings in the goggles, including the C1 button, C2 switch, and the custom mode.

The C1 button and C2 switch can be used as shortcuts for functions such as raising, lowering, or recentering the gimbal or enabling or disabling ESC beeping or the auxiliary bottom light.

The custom mode can be set to Manual or Sport mode.

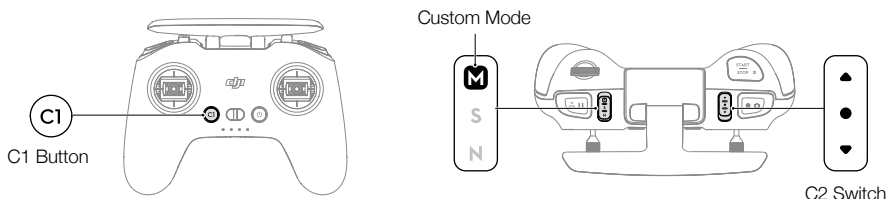

## Remote Controller Alert

The remote controller sounds an alert during RTH. The alert cannot be cancelled. The remote controller sounds an alert when the battery level is 6% to 15%. A low battery level alert can be cancelled by pressing the power button. A critical battery level alert will sound when the battery level is less than 5% and cannot be cancelled.

## Optimal Transmission Zone

The signal between the aircraft and the remote controller is most reliable when the antennas are positioned in relation to the aircraft as shown below.

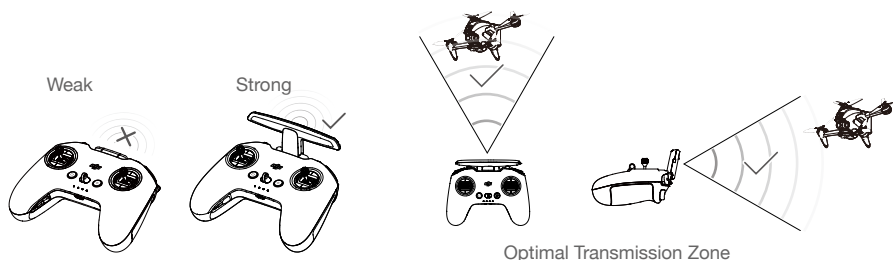

DO NOT use other wireless devices of the same frequency bands in order to avoid interference to the remote controller.

## Stick Adjustment

When using Manual mode, adjust the throttle stick based on your stick mode for a better user experience.

1. Turn the remote controller over and lift the rear rubber grip from the inside groove.

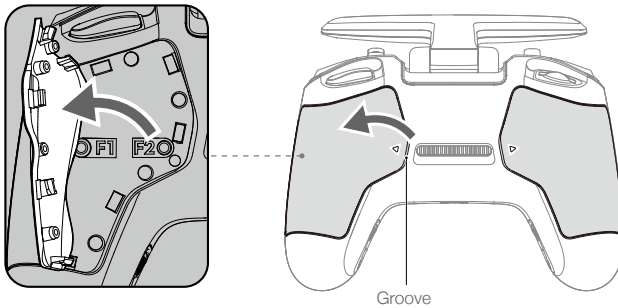

2. The screws under the grip can adjust the corresponding stick on the front of the remote controller. Use an H1.5 hex key to adjust the resistance of the stick and recenter the stick vertically. The control resistance increases when the F1 screw is tightened, and the control resistance decreases when the F1 screw is loosened. The recentering is disabled when the F2 screw is tightened, and the recentering is enabled when the F2 screw is loosened.

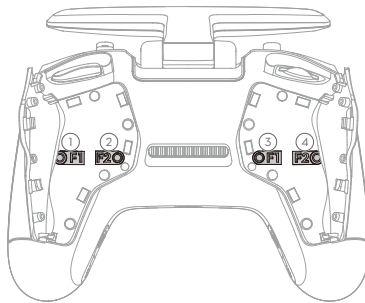

- ① F1 Right Stick Resistance Adjustment Screw (Vertical)
- ② F2 Right Stick Center Adjustment Screw (Vertical)

- ③ F1 Left Stick Resistance Adjustment Screw (Vertical)
- ④ F2 Left Stick Center Adjustment Screw (Vertical)

3. Reattach the rubber grip once the adjustment is complete.

# DJI Fly App

Connect the goggles to the mobile device, launch DJI Fly, and enter the home screen. Tap GO FLY to display the video transmission, which allows you to share the FPV camera view.

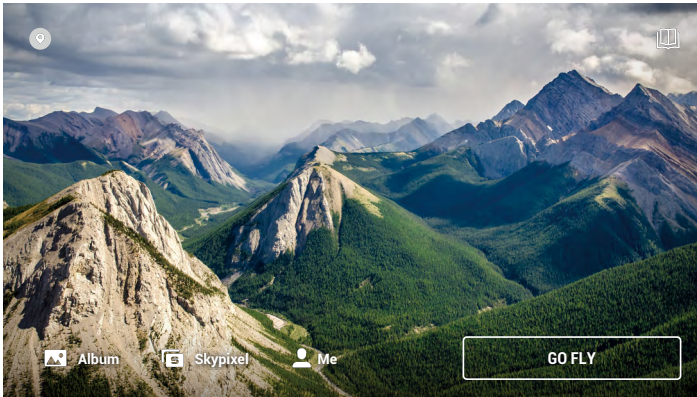

## Fly Spots

View or share nearby suitable flight and shooting locations, learn more about GEO zones, and preview aerial photos of different locations taken by other users.

## Academy

Tap the icon in the top right corner to enter Academy and view product tutorials, flight tips, flight safety, and manual documents.

## SkyPixel

Enter SkyPixel to view videos and photos shared by users.

## Profile

View the account information, flight records, DJI forum, online store, Find My Drone, and other settings.



- Some countries and regions require real-time reporting of the location of the aircraft while flying. As a result, it is necessary to connect the goggles to the mobile device and run DJI Fly. Make sure to check and comply with local regulations.



- Fully charge your mobile device before launching DJI Fly.
  - Mobile cellular data is required when using DJI Fly. Contact your wireless carrier for data charges.
  - DO NOT accept phone calls or use texting features during flight if you are using a mobile phone as your display device.
  - Read all safety tips, warning messages, and disclaimers carefully. Familiarize yourself with the related regulations in your area. You are solely responsible for being aware of all relevant regulations and flying in a way that is compliant.
  - Use the in-app tutorial to practice your flight skills if you have never operated the aircraft or if you do not have sufficient experience to operate the aircraft with confidence.
  - The app is designed to assist your operation. Use sound discretion and DO NOT rely on the app to control the aircraft. The use of the app is subject to DJI Fly Terms of Use and DJI Privacy Policy. Read them carefully in the app.
-

# Flight

Once pre-flight preparation is complete, it is recommended to hone your flight skills and practice flying safely. Make sure that all flights are carried out in an open area. The flight height is limited to 500 m. DO NOT exceed this height. Strictly abide by local laws and regulations when flying. Make sure to read the DJI FPV Disclaimer and Safety Guidelines to understand the safety notices before flying.

## Flight Environment Requirements

1. DO NOT use the aircraft in severe weather conditions including wind speeds exceeding 13.8 m/s, snow, rain, and fog.
2. Only fly in open areas. Tall structures and large metal structures may affect the accuracy of the onboard compass and GPS system. It is recommended to keep the aircraft at least 5 m away from structures.
3. Avoid obstacles, crowds, high voltage power lines, trees, and bodies of water. It is recommended to keep the aircraft at least 3 m above water.
4. Minimize interference by avoiding areas with high levels of electromagnetism such as locations near power lines, base stations, electrical substations, and broadcasting towers.
5. The aircraft and battery performance is subject to environmental factors such as air density and temperature. Be careful when flying 19,685 ft (6,000 m) or more above sea level. Otherwise, the battery and aircraft performance may be reduced.
6. The aircraft cannot use GPS within the polar regions. Use the Downward Vision System when flying in such locations.
7. Fly with caution when taking off from moving surfaces such as a moving boat or vehicle.

## Flight Limits and GEO Zones

Unmanned aerial vehicle (UAV) operators should abide by the regulations from self-regulatory organizations such as the International Civil Aviation Organization, the Federal Aviation Administration, and local aviation authorities. For safety reasons, flight limits are enabled by default to help users operate this aircraft safely and legally. Users can set flight limits on height and distance.

Altitude limits, distance limits, and GEO zones function concurrently to manage flight safety when GPS is available. Only the altitude can be limited when GPS is unavailable.

## Flight Altitude and Distance Limits

Users can change the maximum height and radius limits in the goggles. Once completed, the aircraft flight is restricted to a cylindrical area that is determined by these settings. These limits are detailed in the table below.

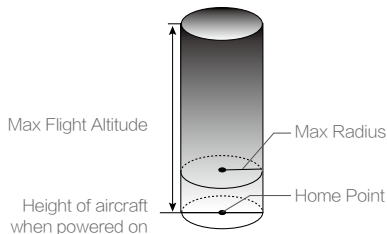

### When GPS is available

	Flight Limits	Goggles	Aircraft Status Indicator
Max Altitude	Aircraft's altitude cannot exceed the specified value	Warning: Height limit reached	Blinks green and red alternately
Max Radius	Flight distance must be within the max radius	Warning: Distance limit reached	

### When GPS is weak

	Flight Limits	Goggles	Aircraft Status Indicator
Max Altitude	Height is restricted to 98 ft (30 m) when the GPS signal is weak.	Warning: height limit reached.	Blinks red and green alternately
Max Radius	The restrictions on the radius are disabled and warning prompts cannot be received in the goggles.		



- There will be no altitude limit if the GPS signal becomes weak during flight as long as the GPS signal display was white or yellow when the aircraft was powered on.
- If the aircraft is in a GEO zone and there is a weak or no GPS signal, the aircraft status indicator will glow red for five seconds every twelve seconds.
- The aircraft can still be controlled if it reaches an altitude or radius limit, but it cannot fly any farther.
- For safety reasons, do not fly close to airports, highways, railway stations, railway lines, city centers, or other sensitive areas. Only fly the aircraft within visual line of sight.

### GEO Zones

All GEO zones are listed on the DJI official website at <https://www.dji.com/flysafe>. GEO zones are divided into different categories and include locations such as airports, airfields where manned aircraft operate at low altitudes, national borders, and sensitive locations such as power plants.

A prompt will appear in the goggles if the aircraft is approaching a GEO zone and the aircraft will be restricted from flying in the area.

### Pre-Flight Checklist

1. Make sure the goggles battery, remote controller, Intelligent Flight Battery, and mobile device are fully charged.
2. Make sure the propellers are mounted correctly and securely.
3. Make sure the Intelligent Flight Battery and goggles battery are properly connected and secure.
4. Make sure the gimbal and camera are functioning normally.
5. Make sure the motors are unobstructed and functioning normally.
6. Make sure that the goggles are functioning normally and display the video transmission.
7. Make sure that the gimbal protector is detached and the camera lens and the Vision System sensors are clean.
8. Make sure that the goggles antennas are installed securely and the remote controller antenna is lifted.
9. Only use genuine DJI parts or parts certified by DJI. Unauthorized parts or parts from non-DJI certified manufacturers may cause the system to malfunction and compromise safety.



## Starting/Stopping the Motors

### Starting the Motors

#### Normal/Sport mode

A CSC is used to start the motors. Push both sticks to the inner or outer bottom corners to start the motors. Once the motors start spinning, release both sticks simultaneously.

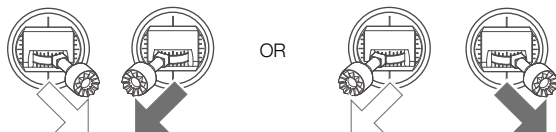

#### Manual mode

Make sure the throttle stick is in the lowest position and press the start/stop button twice to start the motors.

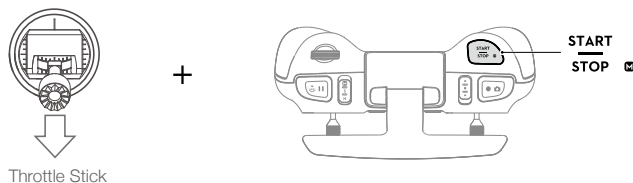

### Stopping the Motors

#### Normal/Sport mode

There are two methods to stop the motors.

Method 1: when the aircraft has landed, push and hold the throttle stick down. The motors will stop after three seconds.

Method 2: when the aircraft has landed, push the throttle stick down, and perform the same CSC that was used to start the motors. Release both sticks once the motors have stopped.

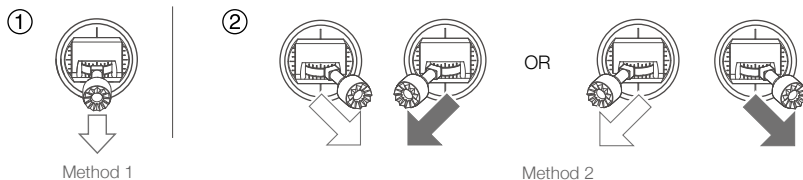

## Manual mode

Press the start/stop button twice to stop the motors once the aircraft has landed.

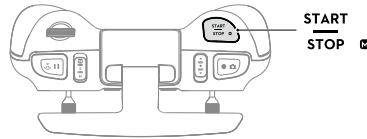

- For flight safety, it is recommended to switch to Normal mode before landing.
- 

## Stopping the Motors Mid-Flight

When using Normal or Sport mode, the motors can only be stopped by performing a CSC mid-flight in an emergency situation such as if the aircraft has a stalled motor, is involved in a collision, is rolling in the air, is out of control, or is ascending or descending quickly. The default setting can be changed in goggles.

When using the Manual mode, press the start/stop button twice to stop the motors at any time.



- Stopping motors mid-flight will cause the aircraft to crash.
- 

## Flight Test

### Takeoff/Landing Procedures

1. Place the aircraft in an open, flat area with the aircraft status indicator facing towards you.
2. Power on the goggles, remote controller, and the aircraft.
3. Wait until the aircraft status indicator blinks green slowly to indicate that the Home Point has been recorded and put on the goggles.
4. Start the motors.
5. Gently push the throttle stick up to take off.
6. Pull the throttle stick down to land the aircraft.
7. Stop the motors after landing.
8. Power off the aircraft, goggles, and remote controller.

### Video Suggestions and Tips

1. The pre-flight checklist is designed to help you fly safely and to ensure that you can record video during flight. Go through the full pre-flight checklist before each flight.
2. Select the gimbal operation mode.
3. It is recommended to use Normal mode to take photos or record videos.
4. DO NOT fly in bad weather conditions such as when it is raining or windy.
5. Choose the camera settings that best suit your needs.
6. Perform flight tests to establish flight routes and to preview scenes.
7. Push the control sticks gently to keep the aircraft movement smooth and stable.
8. When using Manual mode, fly in an open, wide, and sparsely populated environment to ensure flight safety.



It is important to understand the basic flight guidelines, both for your protection and for the safety of those around you.

DO NOT forget to read the **disclaimer and safety guidelines**.

---

# Maintenance

## Goggles

### Cleaning

Make sure to disconnect the goggles from the power outlet before cleaning and make sure that there are no cables connected.

Clean the surface of the goggles with a soft, dry, clean cloth. To clean the foam padding, moisten the cloth with clean water and wipe the foam padding.

### Replacing the Foam Padding

The foam padding is attached to the goggles with Velcro. When replacing the foam padding, peel it gradually from the left or right side. Align the new foam padding with the goggles and press the foam padding down so it is securely attached.

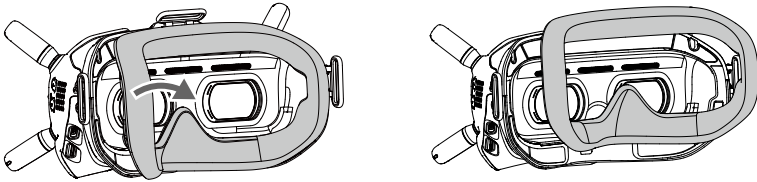

### Maintenance of Lenses

Use a cleaning cloth to wipe the lenses gently.

1. Moisten the cleaning cloth with alcohol or a lens cleaner.
2. Wipe in a circular motion from the center to the outer edges of the lenses.



- DO NOT clean the foam padding with alcohol.
  - The lenses are delicate. Clean them gently. DO NOT scratch them as this will damage the overall viewing experience.
  - Store the goggles in a dry room at room temperature to avoid damage to the lenses from high temperature and humid environments.
-

## Aircraft

Follow the steps below to replace components of the aircraft such as the top shell, gimbal and camera, or landing gear.

### Gimbal and Camera (Incl. Top Shell)

#### Detaching

1. Remove the four M1.6 screws on the front and remove the protective shell.

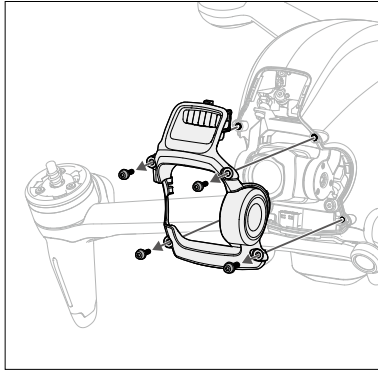

2. Remove the four M2 screws on both sides.

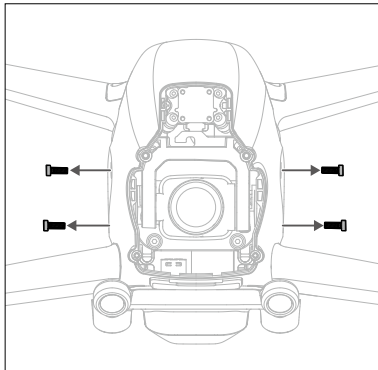

3. Pry a corner of the top shell from the bottom side of the aircraft.

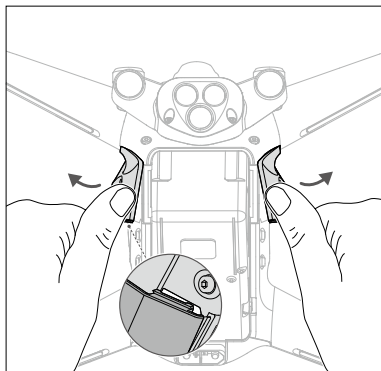

4. Facing the aircraft, hold the front frame arm and push in the direction shown to remove the top shell.

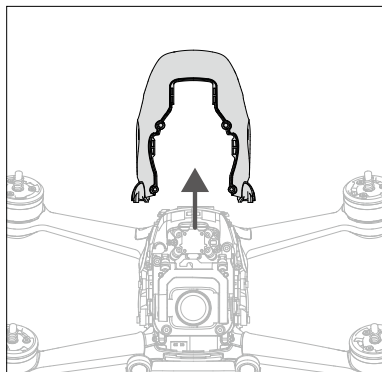
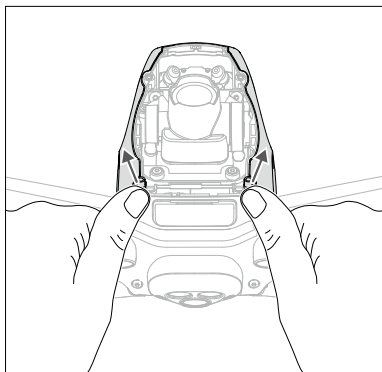

5. Remove the four M2 screws on the front.

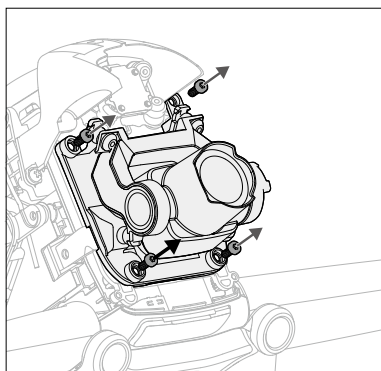

6. Remove the two M1.6 screws on the side before removing the metal piece.

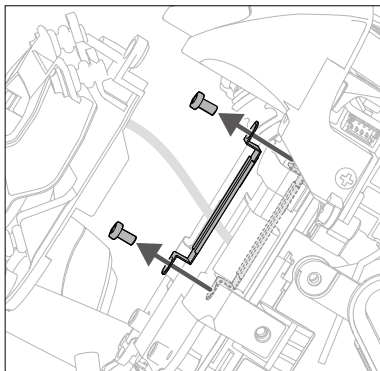

7. Use an appropriate tool to lift and remove the FPC connector on the gimbal and camera.

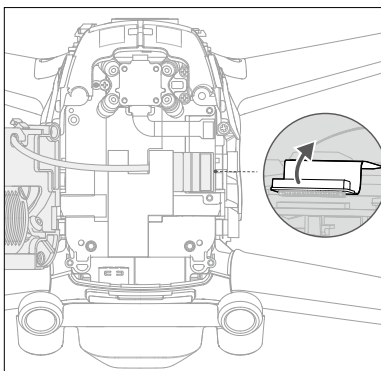

8. Tear off one corner of the fixing tape to remove the gimbal and camera.

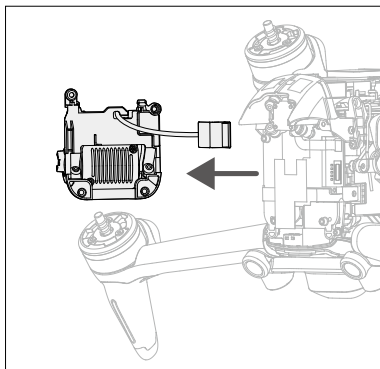
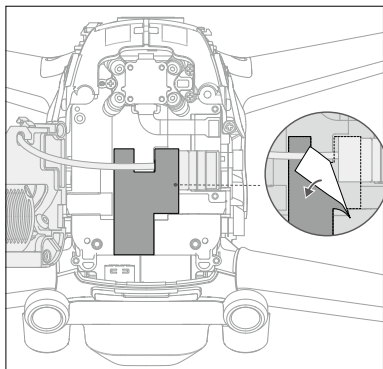

## Installation

1. Prepare a new gimbal and camera, align the connector cable to the position, and secure with fixing tape.

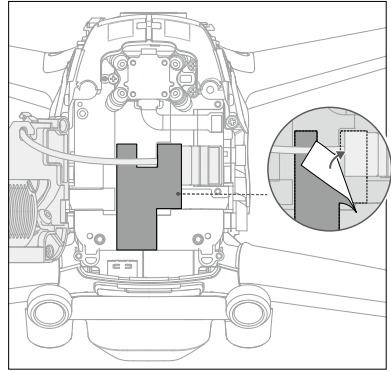
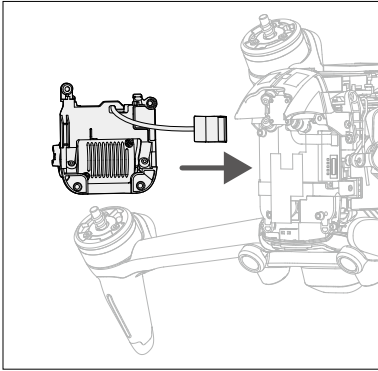

2. Align and press down the FPC connector of the gimbal and camera to make sure they are securely connected.

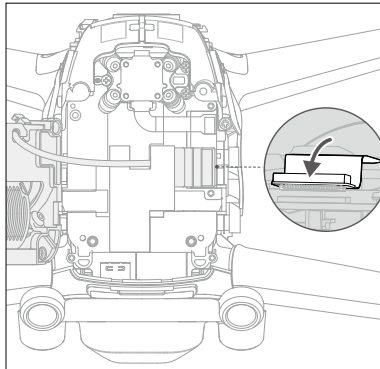

3. Attach the metal plate on the right side and tighten the two M1.6 screws.

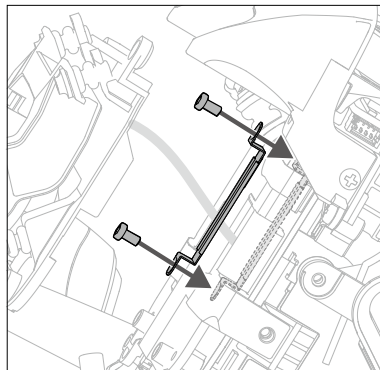

4. Install the gimbal and camera and tighten the four M2 screws.

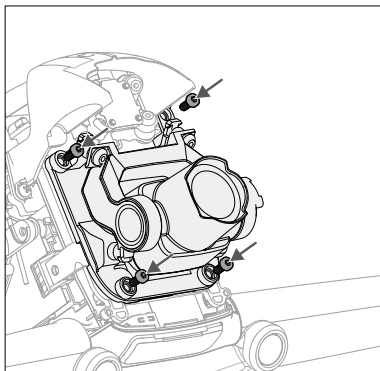

5. Prepare a new top shell to install.

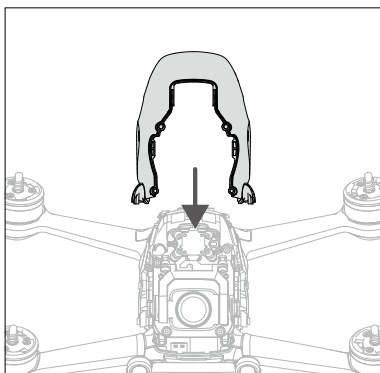

6. Press the following positions in sequence to make sure that the top shell is firmly installed.

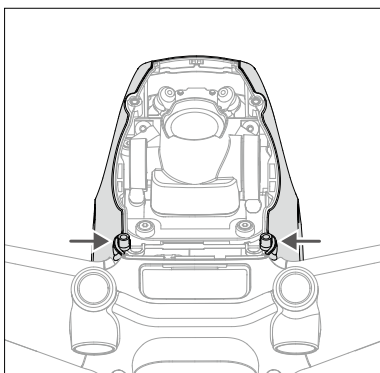
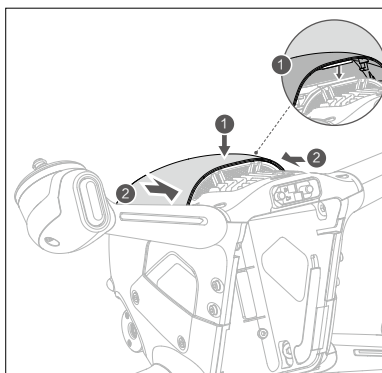



7. Slightly bend the side of the top shell to insert the buckle into the aircraft slot and tighten the four M2 screws on both sides.

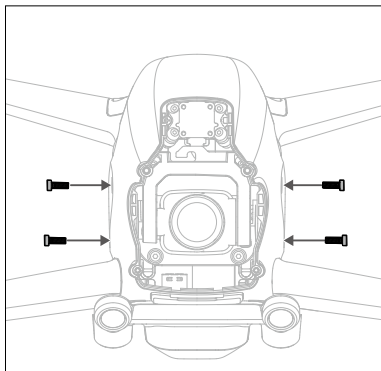
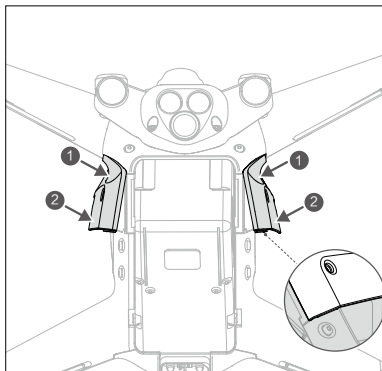

8. Install the protective shell from the top and make sure to align the slots. Tighten the four M2 screws on the front to complete the installation.

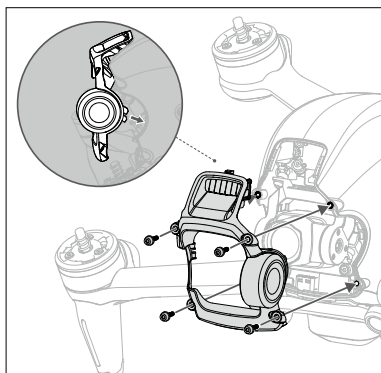

### Calibrating the gimbal and camera

After replacing the gimbal and camera, download the calibration file of the camera to calibrate the gimbal and camera.

1. Power on the aircraft, goggles, and remote controller. Make sure all the devices are linked.
2. Connect the USB-C port of the goggles to the mobile device, run DJI Fly, and follow the on-screen instructions to download the camera calibration file to the aircraft. An internet connection is required for downloading.

## Landing Gear

### Detaching

1. Remove the two M1.6 screws on the bottom of the left landing gear.

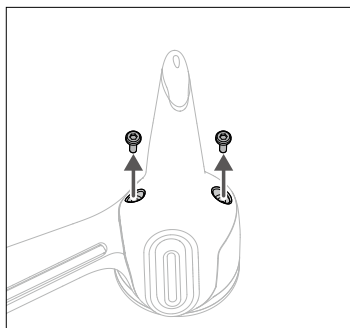

2. Remove the landing gear as shown.

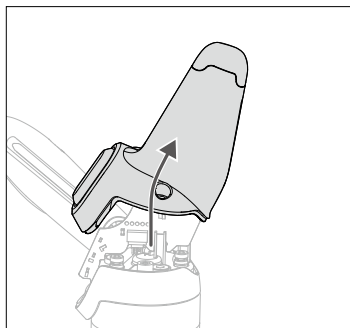

3. Remove the antenna light board of the landing gear.

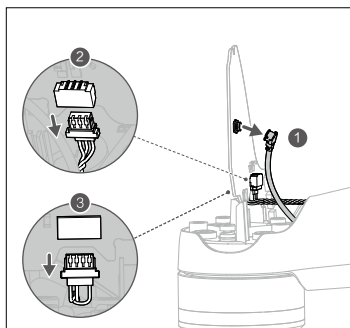

4. Remove the antenna connector and 3-pin and 4-pin light wire connectors on both sides of the board.

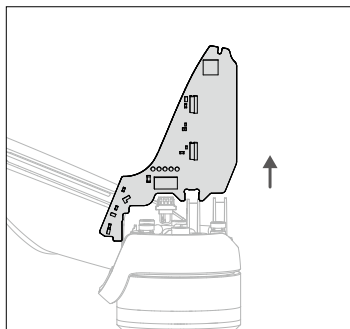

## Installation

1. Check the mark inside the landing gear, and remove the antenna light board from the one marked L. Connect the 3-pin and 4-pin light wire connectors and antenna connector on the bottom of the left front motor and make sure they are secure.

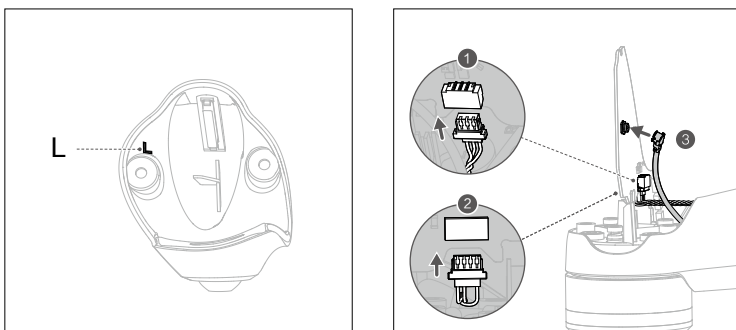

2. Insert the board between the two clamping positions on the motor base.

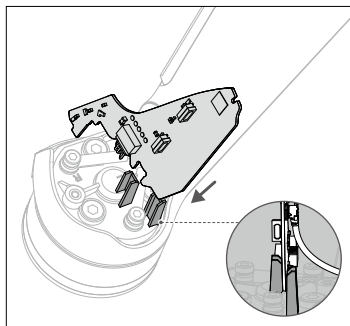

3. Make sure the groove of the landing gear is properly inserted into the corresponding position of the motor base.

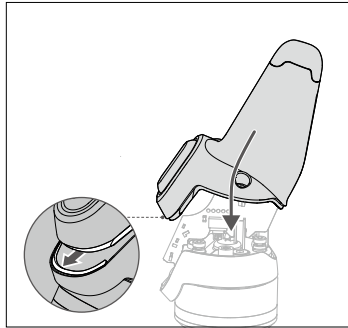

4. Tighten the two M1.6 screws to complete the installation.

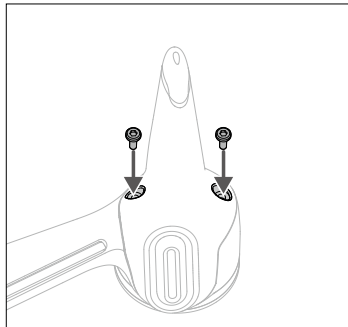

5. Repeat the steps above to install the landing gear on the right side. The landing gear is marked R.

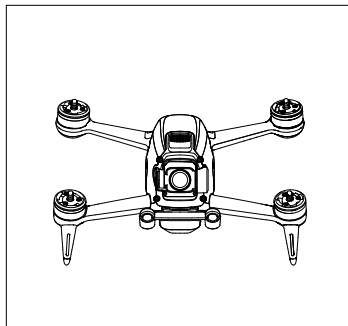

# Appendix

## Specifications

Aircraft	
Takeoff Weight	Approx. 795 g
Dimensions	178×232×127 mm (without propellers) 255×312×127 mm (with propellers)
Diagonal Distance	245 mm
Max Ascent Speed	8 m/s (Normal mode) 15 m/s (Sport mode) No limit (Manual mode)
Max Descent Speed	7 m/s (Normal mode) 10 m/s (Sport mode) No limit (Manual mode)
Max Speed (near sea level, no wind)	15 m/s (Normal mode) 27 m/s (Sport mode) 39 m/s (Manual mode)
Max Horizontal Acceleration (near sea level, no wind)	0-100 kph: 2 s (Manual mode)
Max Service Ceiling Above Sea Level	6000 m
Max Flight Time	Approx. 20 mins (measured while flying at 40 kph in windless conditions)
Max Hover Time	Approx. 16 mins (measured in windless conditions)
Max Flight Distance	16.8 km (measured in windless conditions)
Max Wind Speed Resistance	13.8 m/s
Operating Temperature Range	14° to 104° F (-10° to 40° C)
GNSS	GPS+GLONASS+Galileo
Operating Frequency	2.400-2.4835 GHz; 5.725-5.850 GHz
Transmitter Power (EIRP)	2.4 GHz: ≤31.5 dBm (FCC), ≤20 dBm (CE/SRRC/MIC) 5.8 GHz: ≤31.5 dBm (FCC), ≤25.5 dBm (SRRC), ≤14 dBm (CE)
Hovering Accuracy Range	Vertical: ±0.1 m (with Vision Positioning), ±0.5 m (with GPS Positioning) Horizontal: ±0.3 m (with Vision Positioning), ±1.5 m (with GPS Positioning)
Gimbal	
Mechanical Range	Tilt: -65° to +70°
Controllable Range	Tilt: -50° to +58°
Stabilized System	Single-axis (tilt), electronic roll axis
Max Control Speed	60°/s
Angular Vibration Range	±0.01° (Normal mode)
Electronic Roll Axis	Available (up to an angle of 10°)

<b>Sensing System</b>	
Forward	Precision Measurement Range: 0.5-18 m Obstacle Sensing: Only available in Normal mode FOV: 56° (horizontal), 71° (vertical)
Downward	Infrared Sensor Measurement Range: 10 m Hovering Range: 0.5-15 m Vision Sensor Hovering Range: 0.5-30 m
Auxiliary Bottom Light	Single LED
Operating Environment	Non-reflective, discernible surfaces with diffuse reflectivity of >20%; Adequate lighting of lux >15
<b>Camera</b>	
Sensor	1/2.3" CMOS, Effective Pixels: 12 MP
Lens	FOV: 150° 35mm Format Equivalent: 14.66 mm Aperture: f/2.8 Focus Mode: Fixed focus Focus range: 0.6 m to ∞
ISO Range	100-12800
Electronic Shutter Speed	1/50-1/8000 s
Still Photography Modes	Single shot
Max Image Size	3840×2160
Photo Format	JPEG
Video Resolution	4K: 3840×2160 50/60 p FHD: 1920×1080 50/60/100/120 p
Video Format	MP4/MOV (MPEG-4 AVC/H.264, HEVC/H.265)
Max Video Bitrate	120 Mbps
Color Profiles	Standard, D-Cinelike
RockSteady EIS	Available
Distortion Correction	Available
Supported File Formats	exFAT (recommend) FAT32
<b>Intelligent Flight Battery</b>	
Capacity	2000 mAh
Voltage	22.2 V (standard)
Charging Voltage Limit	25.2 V
Battery Type	LiPo 6S
Energy	44.4 Wh@0.5C
Discharge Rate	10C (typical)
Weight	Approx. 295 g

Charging Temperature Range	41° to 104° F (5° to 40° C)
Max Charging Power	90 W
<b>Goggles</b>	
Weight	Approx. 420 g (incl. headband and antennas)
Dimensions	184×122×110 mm (excl. antennas) 202×126×110 mm (incl. antennas)
Screen Size	2 inch×2
Screen Resolution (Single Screen)	1440×810
Screen Refresh Rate	144 Hz
FOV	30° to 54°; Image size: 50-100%
Interpupillary Distance Range	58-70 mm
Operating Frequency	2.400-2.4835 GHz; 5.725-5.850 GHz
Transmitter Power (EIRP)	2.4 GHz: ≤28.5 dBm (FCC), ≤20 dBm (CE/SRRC/MIC) 5.8 GHz: ≤31.5 dBm (FCC), ≤19 dBm (SRRC), ≤14 dBm (CE)
Communication Bandwidth	Max 40 MHz
Live View Mode	Low-Latency mode (810p 100fps/120fps), Latency < 28 ms High-Quality mode (810p 50fps/60fps), Latency < 40 ms
Max Video Bitrate	50 Mbps
Transmission Range	10 km (FCC); 6 km (CE/SRRC/MIC)
Audio Transmission	Available
Supported Video Recording Format	MOV (Video format: H.264)
Supported Video Playback Format	MP4, MOV, MKV (Video format: H.264; Audio format: AAC-LC, AAC-HE, AC-3, MP3)
Operating Temperature Range	0° to 40° C (32° to 104° F)
Power Input	Recommended: DJI FPV Goggles Battery Third-party batteries: 11.1-25.2 V
<b>Goggles Battery</b>	
Capacity	1800 mAh
Voltage	Max 9 V
Battery Type	LiPo 2S
Energy	18 Wh
Charging Temperature Range	0° to 45° C (32° to 113° F)
Max Charging Power	10 W
Runtime	Approx. 1 hour and 50 minutes (ambient temperature: 25°C, screen brightness: 6)

---

Remote Controller	
Weight	346 g
Dimensions	190×140×51 mm
Operating Frequency	2.400-2.4835 GHz; 5.725-5.850 GHz
Max Transmission Distance (unobstructed, free of interference)	10 km (FCC); 6 km (CE/SRRC/MIC)
Transmitter Power (EIRP)	2.4 GHz: ≤28.5 dBm (FCC), ≤20 dBm (CE/SRRC/MIC) 5.8 GHz: ≤31.5 dBm (FCC), ≤19 dBm (SRRC), ≤14 dBm (CE)
Operating Temperature Range	-10° to 40° C (14° to 104° F)
Battery Charger	
Input	100-240 V, 50/60 Hz, 1.8 A
Output	Main: 25.2±0.15 V, 3.57±0.1 A or 1±0.2 A USB: 5 V/2 A × 2
Rated Power	86 W
Charging Temperature Range	5° to 40° C (41° to 104° F)
Charging Time	Intelligent Flight Battery: approx. 50 minutes Remote Controller: approx. 2 hours 30 minutes Goggles Battery: approx. 2 hours 30 minutes
SD Cards	
Supported SD Cards	microSD Card Max 256 GB, UHS-I Speed Grade 3
Recommended microSD Cards	SanDisk High Endurance U3 V30 64GB microSDXC SanDisk Extreme PRO U3 V30 A2 64GB microSDXC SanDisk Extreme U3 V30 A2 64GB microSDXC SanDisk Extreme U3 V30 A2 128GB microSDXC SanDisk Extreme U3 V30 A2 256GB microSDXC Lexar 667x V30 128GB microSDXC Lexar High Endurance 128G U3 V30 microSDXC Samsung EVO U3 (Yellow) 64GB microSDXC Samsung EVO Plus U3 (Red) 64GB microSDXC Samsung EVO Plus U3 256GB microSDXC Netac 256GB U3 A1 microSDXC



- Aircraft takeoff weight includes battery, propellers, and a microSD card.
- The FOV will be 150° when shooting at 50 or 100 fps. For other frame rates, the FOV will be 142°.
- Devices will take longer to charge if both the Intelligent Flight Battery and remote controller or goggles battery are being charged simultaneously.
- These specifications have been determined through tests conducted with the latest firmware. Firmware updates can enhance performance. It is highly recommended to update to the latest firmware.



## Calibrating the Compass

It is recommended to calibrate the compass in the following situations when flying outdoors:

1. Flying at a location farther than 31 miles (50 km) away from the location the aircraft was last flown.
2. The aircraft has not been flown for more than 30 days.
3. A compass interference warning appears in the goggles and/or the aircraft status indicator blinks red and yellow alternatively.



- DO NOT calibrate the compass in locations where magnetic interference may occur such as close to magnetite deposits or large metallic structures such as parking structures, steel-reinforced basements, bridges, cars, or scaffolding.
- DO NOT carry objects that contain ferromagnetic materials such as mobile phones near the aircraft during calibration.
- It is not necessary to calibrate the compass when flying indoors.

## Calibration Procedure

Choose an open area to carry out the following procedure.

1. Select Settings, Safety, and Compass Calibration in the goggles. The aircraft status indicator will be solid yellow to indicate calibration has started.
2. Hold the aircraft horizontally and rotate it 360°. The aircraft status indicator will turn solid green.
3. Hold the aircraft vertically and rotate it 360° around a vertical axis.
4. If the aircraft status indicator blinks red, calibration has failed. Change your location and try to calibrate again.

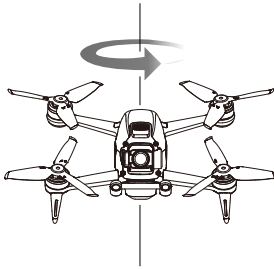

- If the aircraft status indicator blinks red and yellow alternatively after calibration is completed, this indicates that the current location is not suitable for flying the aircraft due to the level of magnetic interference. Choose a new location.



- A prompt will appear in the goggles if compass calibration is required before takeoff.
- The aircraft can take off immediately once calibration is complete. If you wait more than three minutes to take off after calibration, you may need to calibrate again.

### Updating Firmware

Use DJI Fly or DJI Assistant 2 (DJI FPV series) to update the firmware.

#### Using DJI Fly

After powering on the aircraft, goggles, and remote controller, make sure that all devices are linked. Connect the USB-C port of the goggles to the mobile device, run DJI Fly, and follow the prompt to update. An internet connection is required.

#### Using DJI Assistant 2 (DJI FPV series)

Use DJI Assistant 2 (DJI FPV series) to update the aircraft, goggles, or remote controller separately.

1. Power on the device and connect it to a computer with a USB-C cable.
2. Launch DJI Assistant 2 (DJI FPV series) and log in with a DJI account.
3. Select the device and click Firmware Update on the left-hand side.
4. Select the firmware version required.
5. DJI Assistant 2 (DJI FPV series) will download and update the firmware automatically.
6. The device will restart automatically after the firmware update is complete.



- Make sure to follow all the steps to update firmware. Otherwise, the update may fail.
  - The firmware update will take approximately 11 minutes. When updating the firmware, it is normal for the gimbal to go limp, and the aircraft to reboot. Wait until the update is complete.
  - Make sure the computer is connected to the internet.
  - Make sure that the device has sufficient power before updating firmware. Before performing an update, make sure the Intelligent Flight Battery is at least 43% charged and the goggles battery and the remote controller are at least 30% charged.
  - Do not unplug the USB-C cable during an update.
  - If there is an additional battery that needs to be updated after the update is complete, insert it into the aircraft and power on the aircraft. A prompt will appear in the goggles to update the battery. Make sure to update the battery before takeoff.
  - Note that the update may reset various flight parameters such as the RTH altitude and the maximum flight distance. Before updating, take note of your preferred settings and readjust them after the update.
- 

### After-Sales Information

Visit <https://www.dji.com/support> to learn more about after-sales service policies, repair services, and support.

DJI Support

<http://www.dji.com/support>

This content is subject to change.

**Download the latest version from**

**<https://www.dji.com/dji-fpv>**

If you have any questions about this document, please contact  
DJI by sending a message to **[DocSupport@dji.com](mailto:DocSupport@dji.com)**.

Copyright © 2021 DJI All Rights Reserved.