

Ages 14+

Potensic



D58 GPS Drone Operation Guidance

This product supports GPS positioning and is recommended for outdoor flight!

* This drone's WiFi camera is 5G signal , please make sure that your phone are compatible with it.



Catalog

Overview of drone and transmitter	3
Parts install and disassemb	7
Check list before flight	11
Flight steps	11
Function introduction	14
Know your APP	18
To take photo and record video	18
Spare parts	19
Troubleshooting	21

Overview of drone and transmitter

Drone

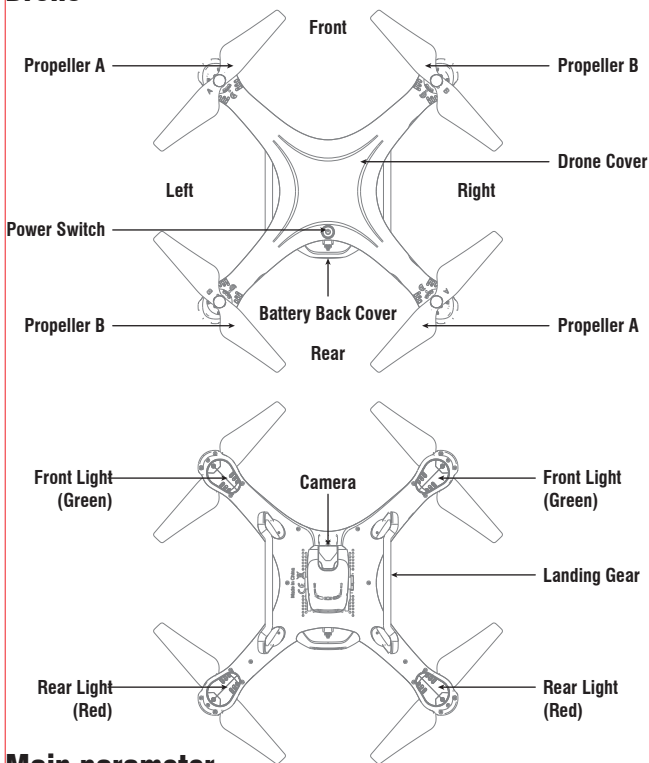

Main parameter

Drone size	423x423x160mm	Flight distance and radius	About 150 m (Without interference)
Drone weight	230 g	Transmission distance and radius	About 150 m (Without interference)
Propeller diameter	190mm		
Flying time	About 16 mins	Camera resolution	1920x1080P
Drone battery	7.4V 1000mAh	Drone control mode	2.4GHz
Battery charging time	About 200 mins	Transmission type	5.8GHz

Exploded view

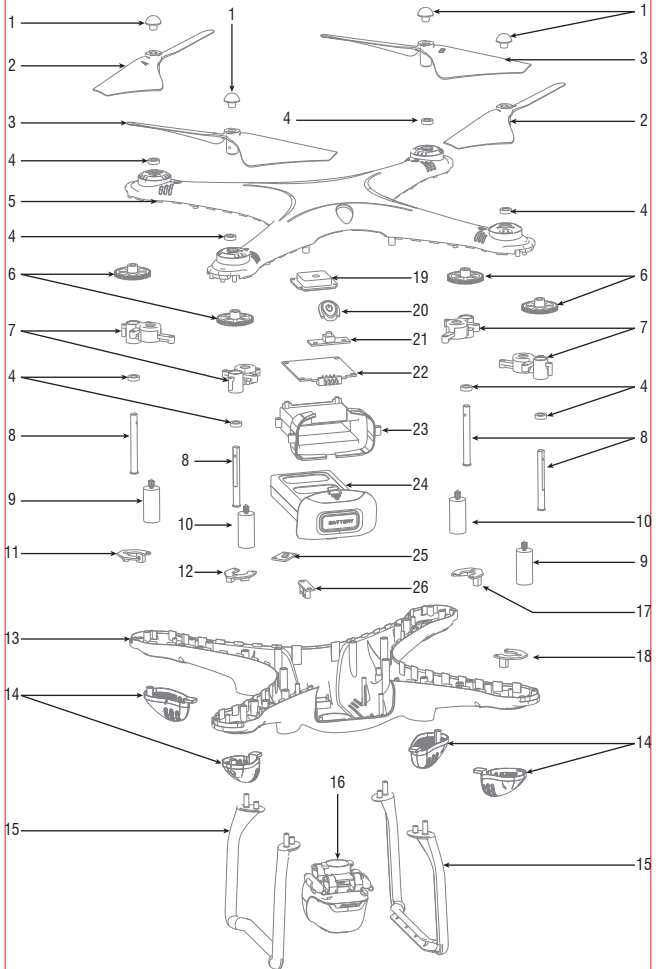

No.	NAME	No.	NAME
1	Propeller plug	13	Drone bottom
2	Propeller A	14	Lamp shade
3	Propeller B	15	Landing gear
4	Bearing	16	Camera box
5	Drone cover	17	Right front LED board(green light/red plug)
6	Gear	18	Right rear LED board(red light/white plug)
7	Motor holder	19	GPS module
8	Shaft	20	Power button
9	A propeller motor (black and white cable/white plug)	21	Power button board
		22	Receiver board
10	B propeller motor (red and blue cable/red plug)	23	Battery holder
		24	Lipo battery
11	Left front LED board (green light/white plug)	25	Magnetic board
		26	Camera adapter
12	Left rear LED board (red light/red plug)		

Transmitter

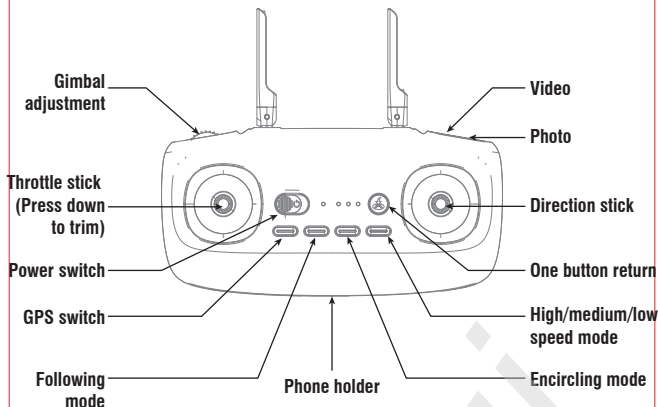

Key function

Left stick	To control the drone up / down / turn left / turn right.
Right stick	To control the drone forward / backward / left side flying / right side flying.
Power switch	Push power switch from left to right to turn on the drone.
Gimbal adjustment key	Slide the key to adjust the camera angle up and down.
GPS switch	Click the key to turn on/off the function of GPS.
The following key	Click the key to enter following function, click again to exit.
Encircling key	Click the key to enter encircling function, click again to exit.
High / middle / low speed	Short press the key to switch the high/ middle/low speed mode.
One key return	When GPS mode, click this button, then the drone starts to return. During returning and click this button again to exit from returning.
Photo	Click this button once to a photo. Click this button constantly, it takes several photos.
Video	Click this button once, it starts to record, and click again to exit.
Trimmer mode key	Press down the key, pull the stick to the direction that needs trimming, then it can turns to the direction you want. Release to exit.

Battery installation

Open the battery cover on the back side of the transmitter and put 4 * AA batteries(not included)into the box in accordance with electrode instructions, showing as picture 1

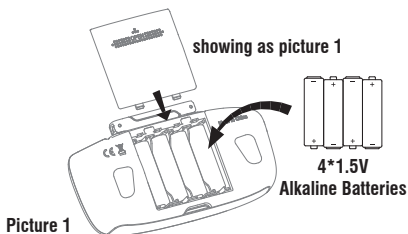

Notice:

1. Make sure the electrodes are correct.
2. Do not mix up the new batteries with the old ones.
3. Do not mix different kinds of batteries.
4. Do not charge the non rechargeable battery.

The installation methods of mobile phone

Hold the bottom buckle of transmitter; Pull down the holder until it can fit the mobile phone; Put on the phone and release the holder; and then the phone is fixed well.

(Picture 2/3)

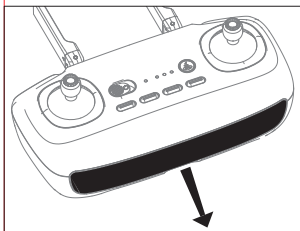

Picture 2

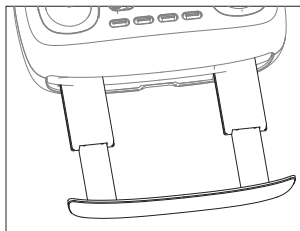

Picture 3

Notice: Don't clamp the buttons of the phone.

Parts install and disassemb

Charging Instruction for Drone Battery

1. Connect the drone battery with USB cable first and then choose one of the methods as below pictures shown to connect with USB plug.
2. The red USB indicator light keeps bright when charging for drone battery and the light turns green when the battery is fully charged.

* For faster charging, it is recommended to use an adapter with 5V 2A output current (not included) to charge the battery



Phone Charger



Power Bank

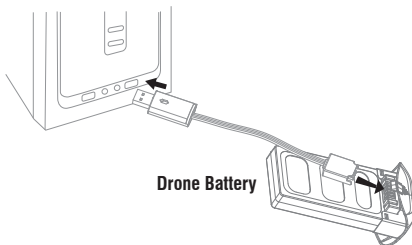

Drone Battery



Computer Charging



Car Charger



Li-Po Battery Disposal & Recycling

Wasted Lithium-Polymer batteries must not be placed with household trash. Please contact local environmental or waste agency or the supplier of your model or your nearest Li-Po battery recycling center.



Landing gear install and disassemb

As the diagram shows, aim the landing gear pillar to the body hole and press down, then tighten the screws on the landing gear. When disassembling, loose the screws and pull out the landing gear(Picture 4).

Note: Make the landing gear close to the drone level, otherwise it will be unstable and affect the stability of the drone.

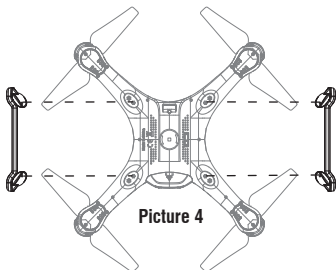

Picture 4

Propeller install and disassembly

1. Use the screw driver counter-clockwise to off the screw and then lift out the damaged propeller (picture 5).
2. Replace with the same new rotating direction propeller, aim at the screw hole to install it, then tighten the screw in clockwise.

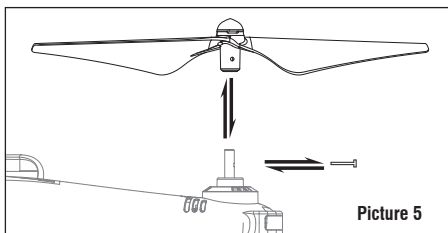

Picture 5

Notice: When installing, please make sure the right installation, or the drone can not fly normally.

Diagram of motor replacement

1. Remove the screw and the lampshade with a screwdriver counter-clockwise, and remove the damaged motor after disconnect the motor terminator.
2. Replace with the same new motor, connect the motor wire, put on the lampshade, then tighten the screws in clockwise.

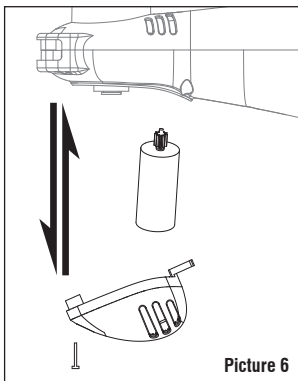

Warning: Please take care and do not to damage the LED board when taking out the motor.

Notice: Please make sure the motor you install is the same rotating direction as the original one. Otherwise, your drone will not fly normally.

Suggestions for motor using:

It's normal that after using for a period of time, the motor performance will decrease, so please purchase a new one for replacement.

Camera box installation diagram

When install the camera box, connect the drone and camera box socket, aim the camera buckle at the drone bottom position (picture 11), and then push in and rotate 90 degrees.

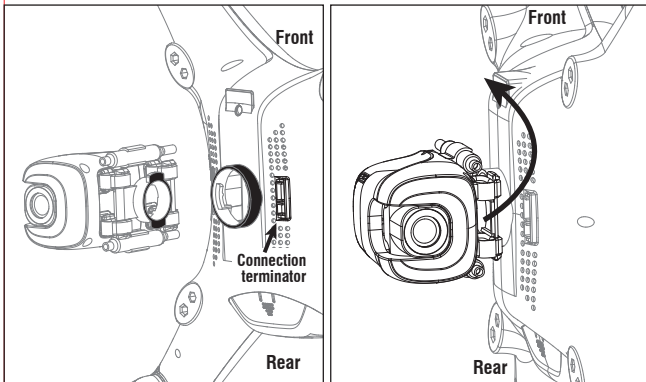
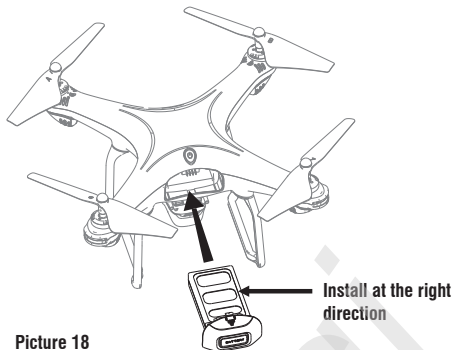

Diagram of battery loading and unloading

When install, it's a must to press down two buckles of the battery cover, then push the battery box into the right place (Picture 18);

When disassembling, press down two buckles of the battery box, then pull the battery box out.



Picture 18

Check List Before Flight

- 1) Make sure the drone and transmitter battery are fully charged.
- 2) Make sure the Throttle Stick of the transmitter is in the middle position.
- 3) Please strictly obey the order of turn on and turn off before operation. Turn on the transmitter power first and then turn on the drone power before flying; turn off the drone power first and then turn off the transmitter power when finish flying. Improper turn on and turn off order may cause the drone out of control and threaten people's safety. Please cultivate a correct habit of turn on/off.
- 4) Make sure the connection is solid between battery and motor etc. The ongoing vibration may cause bad connection of power terminal make the drone out of control.
- 5) Improper operation may cause drone crash, which may arouse motor defective and noise, and then effect the flying status or even stop flying. Please go to the local distributor to buy new parts for replacement so that the drone can return to its best status.

Flight steps

Frequency pairing



Power on the transmitter

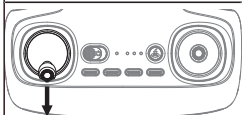

Pull the left stick to the lowest position and let go, the indication light becomes slowly flashing. It indicates the transmitter enters the frequency pairing status.

Hold power button for two seconds to start the drone, when frequency paired successfully, then the left navigation light keeps flashing, while the right navigation light is off. Thus can it enters the state of compass level calibration.



It must be placed on the horizontal ground!

Compass Calibration

Horizontally rotating the drone (picture 19), until the transmitter sounds long “ di... ” , and it shows the horizontal calibration is finished. Left navigation LED gets a solid light and right navigation LED flashes, it enters to vertical calibration status. Vertically rotating the drone (picture 20), until the transmitter sounds long “ di... ” , it shows vertical calibration is finished, and the four navigation LED will flash and rotate.

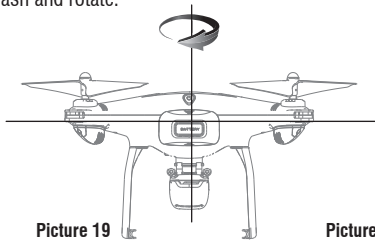

Picture 19
Horizontal Calibration

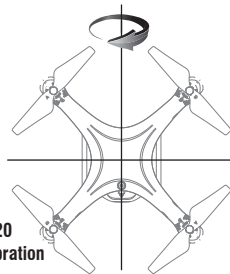

Picture 20
Vertical Calibration

Tips: It's a must to have the compass calibration first each time you start the drone, otherwise the drone can not fly normally.

GPS Signal search

After successfully frequency pairing, the drone enters to search GPS signal automatically.

When the left blue indicator of transmitter turns from flash to solid bright, it indicates GPS signal connection is successfully finished. If not, the drone can't fly up.

Turn on / turn off GPS signal

GPS defaults to be on.

Turn off:

Click the key, the transmitter will make the sound of “di”, the blue indicator of the transmitter is off to indicate that the function of GPS is off.

(The function is suitable for using in the situation of weak GPS signal or indoors; When the GPS function is off, the fixed point function can not work either.)

Turn on:

Repeat above action after five seconds, you can restart the GPS function.



*** The function can only be used when the motor is locked.**

Calibration (This action is used when flying abnormally)

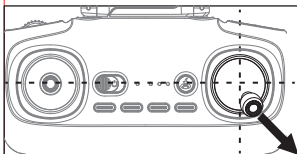

After finishing the compass calibration, push the right stick to the bottom right 45 degrees, the drone LED lights will flash and release it, this means the gyroscope calibration is completed.

Tips: When the drone is fiercely impacted or crashed, it may cause the gyro can not recover and cause difficult to control, if so, then you need to power off and power on again to calibrate. It's a must to put the drone on the horizontal ground.

Unlock/lock the motor

Unlock the motor:

Push the left and right stick inward to the 45 degree angle simultaneously.

Lock the motor:

The operation will cause the motor stop running immediately before the drone takes off.

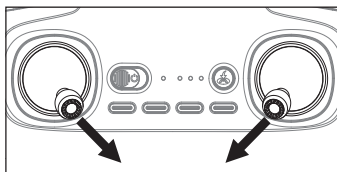

Flying Control

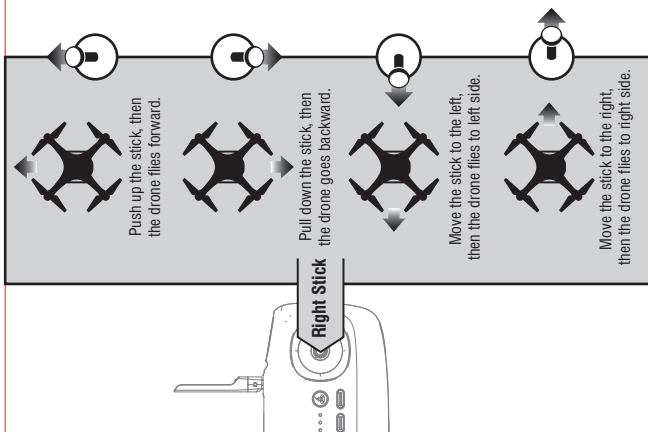

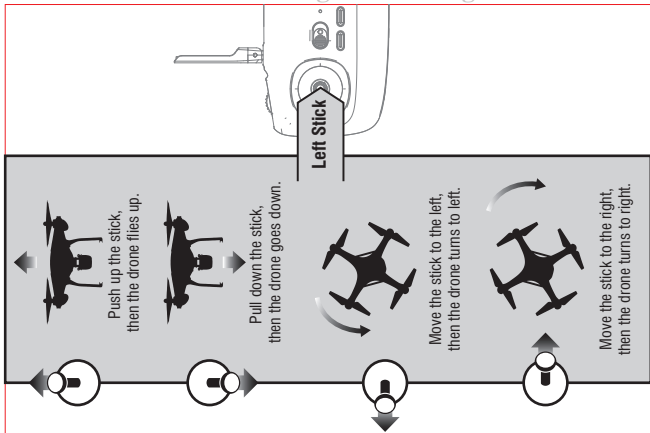

Trimmer mode



Forward and backward trimmer

When take off, if the drone tilts forward, press down the trimmer button, and push the right stick backwards. Otherwise push forwards.

Left and right side flying trimmer

When take off, if the drone tilts to left, then press down the trimmer button and push the right stick backwards to adjust. Otherwise push forwards.

Left and right turning trimmer

When take off, if the drone head rotates to left, then press down the trimmer button and push the left stick to right. Otherwise push to left.

Function Introduction

Record video

While taking video, click the key to start taking video, the transmitter sounds "didi" to remind you, click the key again to stop taking video when you want to stop.

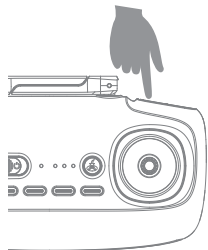

Take Photos

While taking photos, click the key to take a photo. If you click the key continuously, you can take several photos (While taking photos, click the key, the transmitter sounds “di” to remind you).

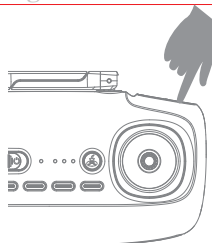

Gimbal Adjustment

Slide the key of gimbal adjustment, the gimbal begins to swing up and down, with video in your phone, you can turn it to the angle you want, loose the key, the gimbal function stops. You can take photos and video at this angle.

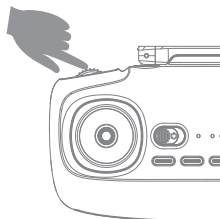

One key returning

During flying, click this button, then the transmitter will beep a long sound “ di ” , it shows the drone starts to return. (When returning, the transmitter will beep “ di” constantly to remind) Return to the beginning. (During returning and click this button again, then exit from returning.)



Notice: While returning, the transmitter stick can not control the drone, you must wait for the drone to go back to the take-off point and keep the same direction of taking off, then the transmitter stick can control the drone again.

Following Function

The function is referred to the mobile phone APP signal, so it's a must to make the drone and APP connected normally, turn on the mobile location service at the same time, otherwise this function is invalid.

While flying, click this button, the drone sounds “ di”, and it enters the function of following and can follow up the user.

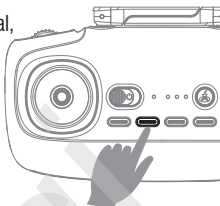

Encircling flight

Click the encircling button, the transmitter will make the sound of “di”, then it goes to the function of encircling flight. The drone will fly to a default location and wait for the direction controlled by the user to adjust the speed and direction of the drone by manipulating the right stick. The default radius is minimum, so the drone flies only along the sub range.

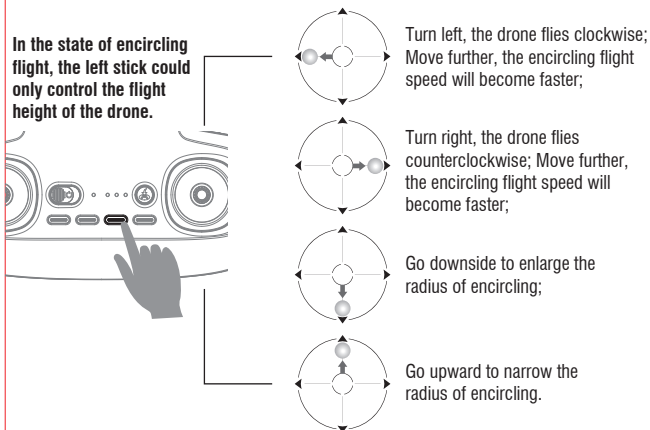

Altitude Hold Mode

Intelligent flight control can calculate the suspended height, it has more stable control performance to make the beginner operate it easily. Release the stick, the drone can automatically suspended to meet the need of single hand manipulation. The aerial photograph is more clear.

Notice: If there's propeller deformation or motor damage, then altitude hold function can not be used. Atmospheric pressure instability or typhoon weather, altitude hold function can not be used normally.

Fixed Point Mode

Intelligent flight control can calculate the suspended height.

Fixed point mode + altitude hold mode = spot hover, make the flight more stable, take photos more clear, and operate more easily.

*** The drone comes with GPS location and fixed-point. So before flying, please make sure that it has connected to GPS signal normally. Or it will become invalid.**

High / Medium/Low Speed Mode Switch

Click this button, then it will sound “di”, it means low speed mode “L”; when it sounds “di.di”, means medium speed “M”; and sounds “di.di.di” means high speed mode “H”.

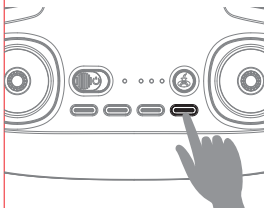

Low Speed Mode (Mode L)

1. Low Speed Mode is suitable for beginner.

Medium speed Mode (Mode M)

2. Medium Speed Mode is suitable for skillful pilots to play in the gentle breeze.

High Speed Mode (Mode H)

3. High Speed Mode is suitable for expert to experience aerial stunt in outdoor.

Low Battery Alarm

When the transmitter is in low battery, it will make the sound of “di...di...di...” constantly to alarm you, now you should land the drone as soon as possible to replace the battery.

While flying, in case that the battery of the drone is low, it will make the sound of “di” .. “di” .. to alarm you, the drone's indicator lights will change from solid bright to flash. After alarm, the drone automatically returned to the take-off point.

Notice: After low-battery alarm, the drone will return home and its controllable range will be within 20 meters radius.

Out of Range Alarm

When the drone flying out of the max remote control distance, the transmitter will beep “didi...didi...didi...” to alarm the user to fly back the drone within range immediately.

Out of Control Protection

Out of control protection refers to the flight control system automatically controls the drone to fly back to the return point after receiving the remote control signal (ie, out of control), and function of landing, which can reduce the loss or fall of the drone.

The drone does not have the function of avoiding obstacles during the uncontrolled return flight. The user can set the return altitude value to avoid obstacles on the way back.

Possibility of entry out of control protection mode

- * The remote control is off.
- * Flight distance exceeds the effective distance of remote control signal transmission.
- * There is an obstacle between the remote control and the drone.
- * Remote control signal is disturbed.

Stuck Protection

1. When the propellers get stuck, then the drone LED will flash quickly and activate stuck protection function and the motors stop running.
2. Pull down the left stick to the lowest position and back to the centre, the drone LED will get a solid light and stuck protection will be released and the drone can fly again.

Know your APP

Download and install APP: potensic

This software is suitable for mobile phones in the IOS and Android system, please download and install it via APP store.

1. The user of ISO mobile phone can surf App Store to search potensic to download.
2. The user of Android can surf Google Play to search potensic to download.
3. You can scan the QR code on the right or the QR code on the color box directly to download and install it.
4. For specific operation, please check help menu in APP.



To take photos and record video

1. Insert the TF card to the slot of camera, make sure the metal side of the card shows as the picture #21.

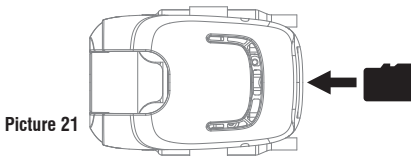

2. The aerial photos will be saved in your mobile phone and the TF card, while the videos only be saved in the TF card. But you can download the video to the mobile phone only when the mobile phone connecting with the drone WiFi and the TF card in the drone camera.

















Tip: Click on the video icon to save a video when finish recording, or the video cannot be saved.











3. Power off the drone first when finish aerial photography. Take out TF card and insert the card to a card reader. Connect the card reader with computer USB port. After a while, view the aerial photography data from "my computer"- "mobile disk".

Tip: Please play the video or photo after coping all aerial photography data to computer and make sure the play software can support relative format.

Spare parts (Sold separately)

For convenience, the spare parts are listed for you to choose, which can be purchased from the local seller.

			
Drone cover	Drone bottom	A propeller	B propeller
			
Landing Gear	Battery holder	Lamp shade	Camera adapter
			
Power board	Magnetic board	Receiver board	GPS Module
			
Left front LED board (Green LED / white socket)	Left rear LED board (Red LED / Red socket)	Right front LED board (Green LED / red socket)	Right rear LED board (Red LED / White socket)

			
A propeller motor (Black&white cable / white socket)	B propeller motor (Red&blue cable / red socket)	Lipo battery	USB charger
			
Gear	Shaft	TF card	Card reader
			
Screw driver	Camera box	Transmitter	

Important Notice

Our company's products are improving all the time, design and specifications are subject to change without notice.

All the information in this manual has been carefully checked to ensure accuracy, if any printing errors, our company reserve the final interpretation right.

Troubleshooting

No.	Problem	Problem Cause	Solution
1	The controller indicator light is off.	1. Low battery.	1. Replace the controller battery.
		2. The batteries are incorrectly positioned.	2. Install the batteries following the polarity indicators.
		3. Poor Contact.	3. Clean the dirt between the battery and the battery contacts.
2	Failed to pair the drone with the controller.	1. Indicator light is off.	1. The same as above.
		2. There is an interfering signal nearby.	2. Restart the drone and power on the controller.
		3. Mis-operation.	3. Operate the drone step by step in accordance with the user manual.
		4. The electronic component is damaged for fiercely crash.	4. To buy spare parts from local seller and replace damaged parts.
3	The drone is under-powered or can not fly.	1. The propeller is seriously deformed.	1. Replace the propeller.
		2. Low battery.	2. Charge the drone battery.
		3. Incorrect installation of propeller.	3. Install the propeller in accordance with the user manual.
4	The drone could not hover and tilts to one side.	1. Improper Calibration.	1. Please refer to the Calibration Instruction.
		2. The propeller is seriously deformed.	2. Replace the propeller.
		3. The motor holder is deformed after violent crash.	3. Replace the motor holder parts.
		4. The gyroscope did not reset after a serious crash.	4. Put the drone on the flat ground for about 10 minutes or restart the drone to calibrate again.
		5. Motor is damaged.	5. Replace the motor.
		6. No proofreading compass.	6. Re proofreading the compass.
5	The drone indicator light is off.	1. Low battery.	1. Recharge the drone battery.
		2. The battery is expired or over discharge protection.	2. Buy a new battery from local seller to replace the battery or charge the battery in accordance with the use manual.
		3. Poor contact.	3. Connect and disconnect the battery.
6	Could not see the picture.	1. There is an interfering signal nearby.	1. Practice and read the cellphone controlling instruction carefully.
		2. Camera is damaged.	2. Replace Camera.
7	Hard to control by cellphone.	Not experienced enough.	Practice and read the cellphone controlling instruction carefully.
8	Can't altitude hold.	1. The propeller is seriously deformed.	1. Replace propeller.
		2. The motor is damaged.	2. Replace the motor.
		3. Atmospheric pressure is not stable.	3. Refer to "Altitude Hold Mode" instruction.
9	Can't position hold.	1. Whether the GPS has connected or not.	1. Search again to connect the GPS signal.
		2. Disorder after taking off.	2. Compare the compass again; If not, replace a new geomagnetic plate.
10	Searched but could not find the GPS signal	GPS module is damaged.	Please replace a new one.

FCC Note

This equipment has been tested and found to comply with the limits for a Class B digital device, pursuant to Part 15 of the FCC Rules. These limits are designed to provide reasonable protection against harmful interference in a residential installation. This equipment generates uses and can radiate radio frequency energy and, if not installed and used in accordance with the instructions, , which may cause harmful interference to radio communications. However, there is no guarantee that interference will not occur in a particular installation. If this equipment does cause harmful interference to radio or television reception, which can be determined by turning the equipment off and on, the user is encouraged to try to correct the interference by one or more of the following measures:

- Reorient or relocate the receiving antenna.
- Increase the separation between the equipment and receiver.
- Connect the equipment into an outlet on a circuit different from that to which the receiver is connected.

WARNING: Changes or modifications not expressly approved by the party responsible for compliance could void the user's authority to operate the equipment.

FCC Notice:

The equipment may generate or use radio frequency energy. Changes or modifications to this equipment may cause harmful interference unless the modifications are expressly approved in the instruction manual. Modifications not authorized by the manufacturer may void user's authority to operate this device.

This device complies with Part 15 of the FCC Rules. Operation is subject to the following two conditions:

- (1) This device may not cause harmful interference.
- (2) This device must accept any interference received, including interference that may cause undesired operation.

FCC Radiation Exposure Statement

The device has been evaluated to meet general RF exposure requirement. The device can be used in portable exposure condition with out restriction.



MADE IN CHINA

