

1 Charge the Flight Battery (~75 min)

Charger LED codes

- Power connected
- Charging
- Balancing
- Charging complete

CAUTION: All instructions and warnings must be followed exactly. Mishandling of Li-Po batteries can result in a fire, personal injury and/or property damage.

2 Install and Charge the ST-10+ Transmitter Battery

(d) Connect the USB cable to an appropriate USB power source and to the charge port of the transmitter. The screen will show a charging battery icon. Disconnect the USB cable when the onscreen battery icon shows full capacity.

- (a) Insert the LiPo battery into the ST-10+ transmitter.
- (b) Connect the battery lead to the transmitter noting the correct polarity.
- (c) Close the battery compartment.

3 Install the propellers

- The props and motor pods have a letter code, either "A" or "B" molded in. Match the "A" props to the "A" motor pods and the "B" props to the "B" motor pods.
- The "A" props thread on counter-clockwise.
- The "B" props thread on clockwise.
- Tighten the props only finger tight. DO NOT overtighten.

4a Remove the Gimbal Cover

Tip: Replace the gimbal cover after flying for storage and transportation of the quadcopter to protect the gimbal.

4b Extend the GPS Mast

6 Power Up

- (a) Place the quadcopter outdoors on a flat, level surface.
- (b) Set the top right transmitter switch to Smart.
- (c) Power on the transmitter.
- (d) Power on the quadcopter.
- (e) The LEDs will show green, rotating counter-clockwise around the motor pods while the quadcopter acquires a gps signal. The front LEDs will show white and the rear will show green when the quadcopter is ready for flight.
- (f) Perform the compass calibration as shown in the video at www.KnowChroma.com.

(d) Perform the compass calibration as shown in the video at www.KnowChroma.com.

7 Connect the CGO2+ Camera to the ST-10+ via Wi-Fi

After the CGO2+ camera powers on, the LED on the gimbal will glow red for approximately 40 seconds. When the LED changes to yellow, complete the following steps to bind the CGO2+ to the ST-10+:

- Select Flight Settings from the main menu on the ST-10+.
- Select the Bind option.
- Under Camera, select the CGO2 network (CGO2_*****).
- Touch the Password line on the screen and enter the password "1234567890" on the touchscreen.
- Select OK.
- The ST-10+ will indicate a successful connection. Select OK.
- Return to the Main Menu.

The live video feed is now visible on the ST-10+ display.

Double tap on the image to expand the video to fill the display. Double tap again to return to the main menu with live video.

5 Install the Flight Battery

- Slide the fully charged battery in until it locks.
- Remove the battery by pressing the locking tab and sliding the battery to the rear of the quadcopter.

8 Understanding the Flight Modes

Smart Mode

- A green LED cycles around the motor pods counter-clockwise until GPS is acquired.
- Once GPS is acquired, the front LEDs are white and the rear are green.
- Intended for the beginner pilot.
- Maximum distance of 100 m from the pilot.

For best results while using Smart Mode, it is recommended that the pilot always turn to face the quadcopter while flying.

AP Mode

- A purple LED cycles around the motor pods counter-clockwise until GPS is acquired.
- Once GPS is acquired, the front LEDs are white and the rear are purple.
- Intended for the intermediate pilot.
- Maximum distance of 100 m from the pilot.

Stick commands move the Chroma™ quadcopter relative to the pilot location

Stick commands move the Chroma™ quadcopter relative to its orientation

NOTICE: If the Chroma™ quadcopter loses GPS signal while flying in either Smart or AP Mode, the LEDs will flash rapidly for 2 seconds and then once every second. The quadcopter will default to a stable flight mode with similar control response as AP Mode. Return Home will not function. Please familiarize yourself with the controls in AP Mode to ensure a safe return of the quadcopter in the event of GPS signal loss.

For information on additional flight modes, including "Follow Me," see the online video at www.KnowChroma.com.

9 Placement at startup

CAUTION: When the home location is set, the quadcopter must be approximately 16 feet (5 meters) from where the pilot will stand during flight, pointing away from the pilot. If the aircraft is pointed in any other direction, the **SAFE Circle™** feature will not function as expected and may result in personal injury or damage to property. Once the aircraft's motors are started, do not change your position.

10a Motor Start

Hold 3 seconds

10b Motor Stop

Hold until the motors stop

NOTICE: Do not press the Motor Stop button while the aircraft is airborne. The motors could stop, causing the aircraft to crash.

WARNING: Stopping the motors while the quadcopter is still in flight will cause the quadcopter to crash. Crash damage is not covered under warranty.

11 Throttle control (RTF)

Left transmitter stick

- To maintain the current altitude, allow the left transmitter stick to return to center.

Climb

Descend

12 Flying and Landing

NOTICE: If you begin to lose control, release the control sticks and the model will self-level.

Pay close attention to the LEDs while flying. If at any time the LEDs indicate the flight battery voltage is low, as shown in the LED reference guide, land the quadcopter immediately and charge the flight battery.

To land, you may either slowly lower the left transmitter stick to descend and land, stopping the motors as shown in step 10b:

or you may select "Return Home" on the top right switch on your transmitter:

The quadcopter will return to the start position, land and stop the motors. You may cancel the return to home function by switching back to Smart or AP Mode on the top right switch on your transmitter.

NOTICE: Return home will only function if the quadcopter has GPS lock.

13 Controlling the Camera

Use the buttons on the top of the ST-10+ to control the camera functions.

Use the Camera Tilt Slider to adjust the vertical angle of the camera gimbal.

For further information on controlling the CGO2 camera with the ST-10 Ground Station, see the online video at www.KnowChroma.com.

14 After Your Flight

NOTICE

All instructions, warranties and other collateral documents are subject to change at the sole discretion of Horizon Hobby, LLC. For up-to-date product literature, visit horizonhobby.com and click on the support tab for this product.

Meaning of Special Language

The following terms are used throughout the product literature to indicate various levels of potential harm when operating this product:

NOTICE: Procedures, which if not properly followed, create a possibility of physical property damage AND a little or no possibility of injury.

CAUTION: Procedures, which if not properly followed, create the probability of physical property damage AND a possibility of serious injury.

WARNING: Procedures, which if not properly followed, create the probability of property damage, collateral damage, and serious injury OR create a high probability of superficial injury.

WARNING: Read the ENTIRE instruction manual to become familiar with the features of the product before operating. Failure to operate the product correctly can result in damage to the product, personal property and cause serious injury.

This is a sophisticated hobby product. It must be operated with caution and common sense and requires some basic mechanical ability. Failure to operate this Product in a safe and responsible manner could result in injury or damage to the product or other property. This product is not intended for use by children without direct adult supervision. Do not use with incompatible components or alter this product in any way outside of the instructions provided by Horizon Hobby, LLC. This manual contains instructions for safety, operation and maintenance. It is essential to read and follow all the instructions and warnings in the manual, prior to assembly, setup or use, in order to operate correctly and avoid damage or serious injury.

Age Recommendation: Not for children under 14 years. This is not a toy.

CAUTION: The ESCs for the Chroma quadcopter are not compatible with any other product, and the Chroma quadcopter is not compatible with any other ESCs. Use of any other ESCs on the Chroma quadcopter will cause a crash, which may result in property damage and/or personal injury.

WARNING AGAINST COUNTERFEIT PRODUCTS: If you ever need to replace a Spektrum component found in a Horizon Hobby product, always purchase from Horizon Hobby, LLC or a Horizon Hobby authorized dealer to ensure authentic high-quality Spektrum product. Horizon Hobby, LLC disclaims all support and warranty with regards, but not limited to, compatibility and performance of counterfeit products or products claiming compatibility with DSM or Spektrum technology.

General Safety Precautions and Warnings

- Always keep a safe distance in all directions around your model to avoid collisions or injury. This model is controlled by a radio signal subject to interference from many sources outside your control. Interference can cause momentary loss of control.
- Always operate your model in open spaces away from full-size vehicles, traffic and people.
- Always carefully follow the directions and warnings for this and any optional support equipment (chargers, rechargeable battery packs, etc.)
- Always keep all chemicals, small parts and anything electrical out of the reach of children.
- Always avoid water exposure to all equipment not specifically designed and protected for this purpose. Moisture causes damage to electronics.
- Never place any portion of the model in your mouth as it could cause serious injury or even death.
- Never operate your model with low transmitter batteries.
- Always keep aircraft in sight and under control.
- Always move the throttle fully down at rotor strike.
- Always use fully charged batteries.
- Always keep transmitter powered on while aircraft is powered.
- Always remove batteries before disassembly.
- Always keep moving parts clean.
- Always keep parts dry.
- Always let parts cool after use before touching.
- Always remove batteries after use.
- Never operate aircraft with damaged wiring.
- Never touch moving parts.

Charging Warnings

WARNING: Failure to exercise caution while using this product and comply with the following warnings could result in product malfunction, electrical issues, excessive heat, FIRE, and ultimately injury and property damage.

- **NEVER LEAVE CHARGING BATTERIES UNATTENDED.**
- **NEVER CHARGE BATTERIES OVERNIGHT.**
- Never attempt to charge dead, damaged or wet battery packs.
- Never attempt to charge a battery pack containing different types of batteries.
- Never allow children under 14 years of age to charge battery packs.
- Never charge batteries in extremely hot or cold places or place in direct sunlight.
- Never charge a battery if the cable has been pinched or shorted.
- Never connect the charger if the power cable has been pinched or shorted.
- Never attempt to dismantle the charger or use a damaged charger.
- Never drop charger or batteries.
- Always use only rechargeable Li-Po batteries designed for use with this type of charger.
- Always inspect the battery before charging.
- Always keep the battery away from any material that could be affected by heat.
- Always monitor the charging area and have a fire extinguisher available at all times.
- Always end the charging process if the battery becomes hot to the touch or starts to change form (swell) during the charge process.
- Always connect the charge cable to the charger first, then connect the battery to avoid short circuit between the charge leads. Reverse the sequence when disconnecting.
- Always connect the positive red leads (+) and negative black leads (-) correctly.
- Always disconnect the battery after charging, and let the charger cool between charges.
- Always charge in a well-ventilated area.
- Always terminate all processes and contact Horizon Hobby if the product malfunctions.

Front

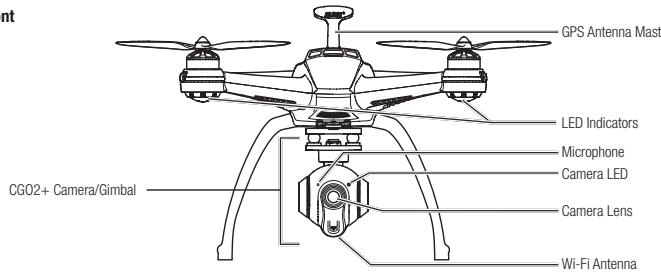

Back

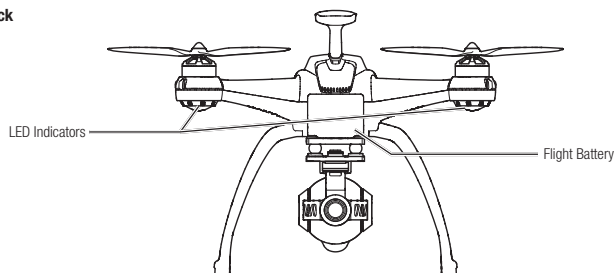

Top

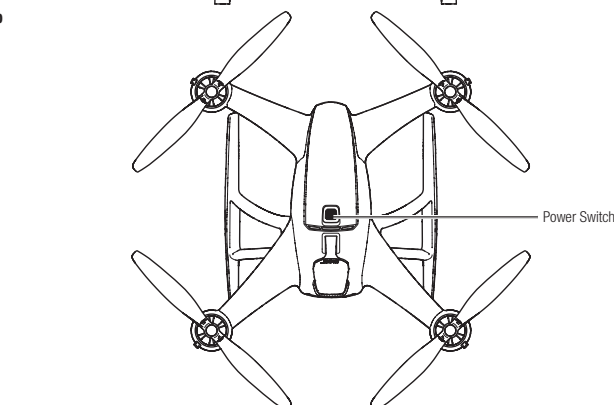

* This aircraft is not compatible with Spektrum™ DSM®, DSM2® or DSMX® technology.

www.KnowChroma.com

ST-10+ Personal Ground Station Transmitter*

Front

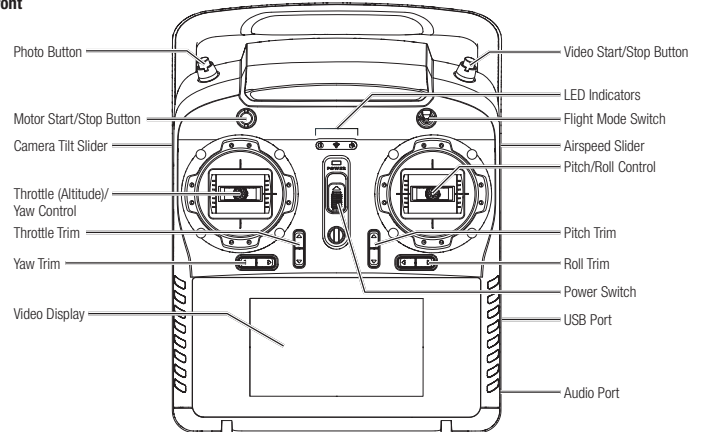

Left

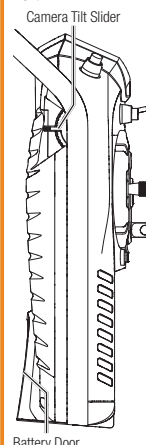

Transmitter LEDs

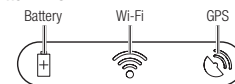

Right

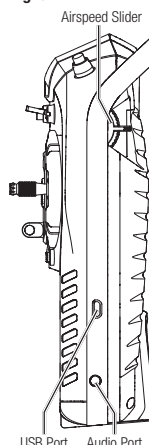

Video Display

