

BABYHAWK II HD

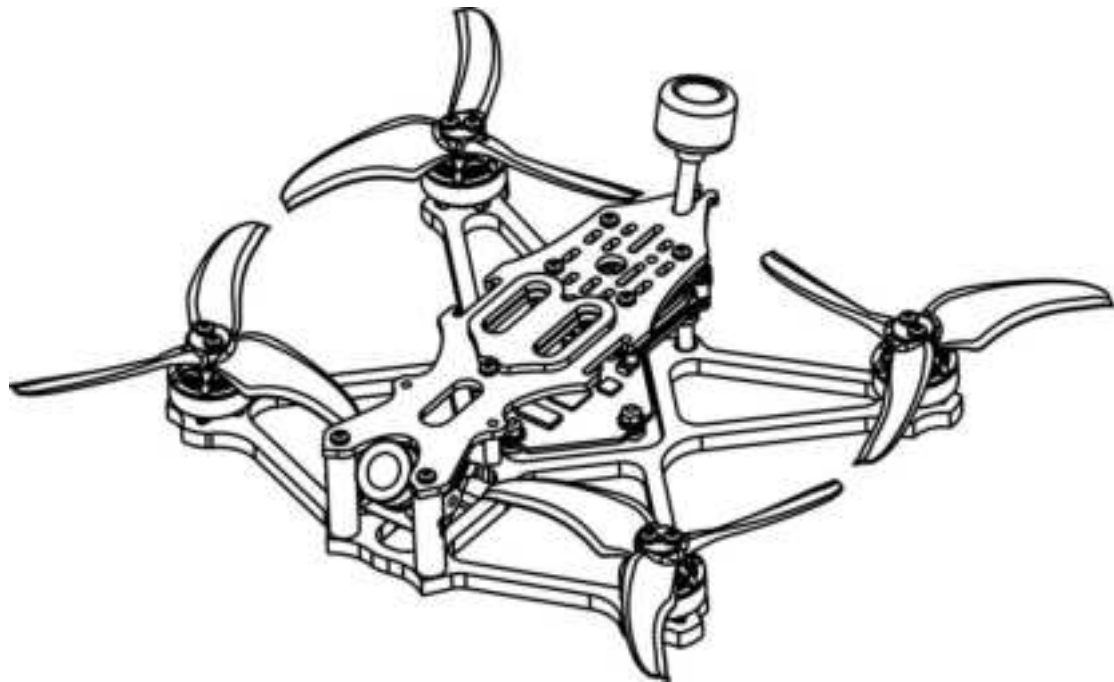

Thanks for purchasing the Babyhawk II HD .
Designed in California, assembled in China.

Disclaimer

Please read the disclaimer carefully before using this product. By using this product, you hereby agree to this disclaimer and signify that you have read them carefully and completely. This product is not suitable for people under the age of 18. Adult supervision is highly recommended for kids under the age of 18.

Our Babyhawk II HD features open-source flight controller and Electronic Speed Controllers to meet the FPV enthusiasts' need to upgrade their quad.

Please read the instruction manual and warnings carefully. Before every flight, make sure the battery is fully charged and power connections are secure. DO NOT fly around crowds, children, animals or objects. EMAX ACCEPTS NO LIABILITY FOR DAMAGE(S) OR INJURIES INCURRED DIRECTLY OR INDIRECTLY FROM THE USE OF THIS PRODUCT.

Precautions

Please follow the instructions to assemble and to operate this product in a proper way.

Pilots do not use this product if you have physical or mental illness, dizziness, fatigued, or use while under the influence of alcohol or drugs.

Please fly in a safe area away from people

Do not modify or use other parts and accessories not approved for the use of EMAX.

Do not use this product in harsh environments (such as winds, rain, lightning, snow, etc.).

Do not use this product in a strong electromagnetic environment.

Support

Please visit emax-usa.com or emaxmodel.com for any updates or support needs.

Table of Contents

Disclaimer.....	1
Precautions.....	1
Support.....	1
Product specification.....	1
Babyhawk II HD.....	1
Parameter.....	1
Product list.....	1
Babyhawk II HD Structure.....	2
Babyhawk II HD.....	3
Propeller Direction and Mounting.....	3
<u>Babyhawk II HD All-in-One Flight Controller</u>	4
<u>Emax Babyhawk II HD Flight Controller (FC)</u>	4
<u>Stock Flight Controller Settings</u>	4
Adjusting Software Settings (Betaflight Configurator).....	4
Reprogramming <u>Babyhawk II HD</u> Flight Controller.....	4
Set the Correct Settings.....	5
Flight.....	7
Radio Stick Controls.....	7
Left Stick Diagram.....	7
Right Stick Diagram.....	7
Fly Babyhawk II HD.....	8
Arming.....	8
Flying Modes.....	8
Line of Sight Flying.....	8
First Person View (FPV) Flying.....	8

Product specification

Babyhawk II HD	Parameter
Diagonal wheelbase (without paddles)	155mm
Maximum size of the aircraft (without antenna, cable tie)	210mm
Aircraft weight (without battery)	139g±2g
Motor	ECO1404-3700KV
Propeller	Avan 3.5 inch Propeller
Main Flight Controller	F4 (STM32F411 firmware) 4 in 1 25A ESC
Camera& Video Transmitter	Caddx Vista HD VTX + Polar cam Camera

Product list

1. Babyhawk II HD × 1
2. VISTA KIT Instruction manual × 1
3. Instruction manua cardl × 1
4. Extra Propeller (1x CW, 1x CCW)
5. Screw pack x 1

Babyhawk II HD Structure

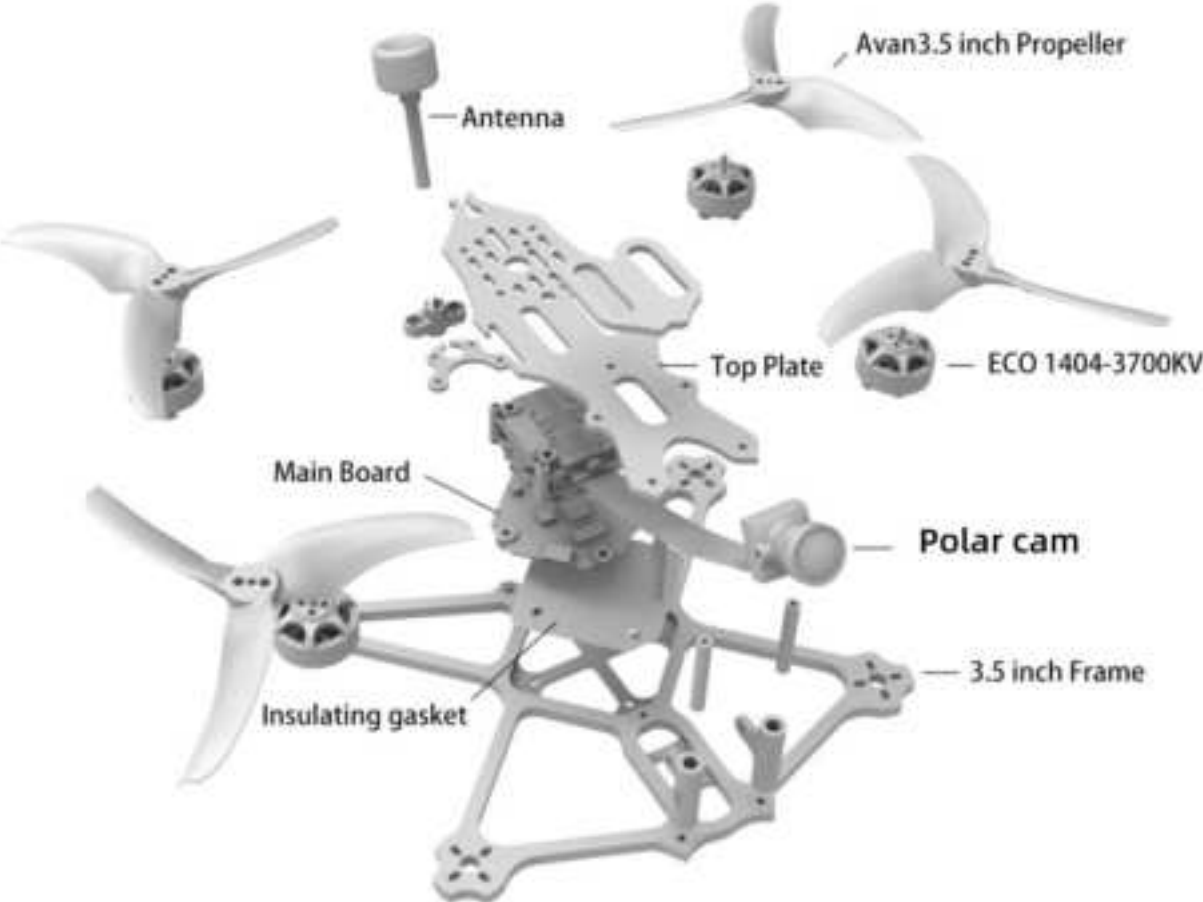

Babyhawk II HD

Propeller Direction and Mounting

There are 2 spinning directions for Babyhawk II HD propellers, Clockwise (CW) and Counter-Clockwise (CCW). When Buying a set of propellers, 2 CW and 2 CCW will be given. The blunt leading edge indicates the direction the propeller is suppose to rotate as compared to the sharp trailing edge. When mounting propellers please make sure the correct orientation shown in the diagram below.

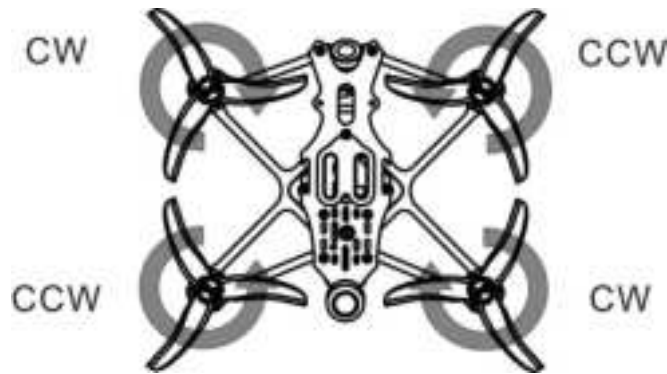

Caution: Failure to mount the propellers in the correct orientation will cause Babyhawk II HD to not fly correctly and with no control. Please double check for the correct orientation.

1. Push the propeller down the motor
2. Tighten M2 screw and secure it.
3. Periodically check nut tightness to ensure it will stay tight during flight.

Babyhawk II HD All-in-One Flight Controller

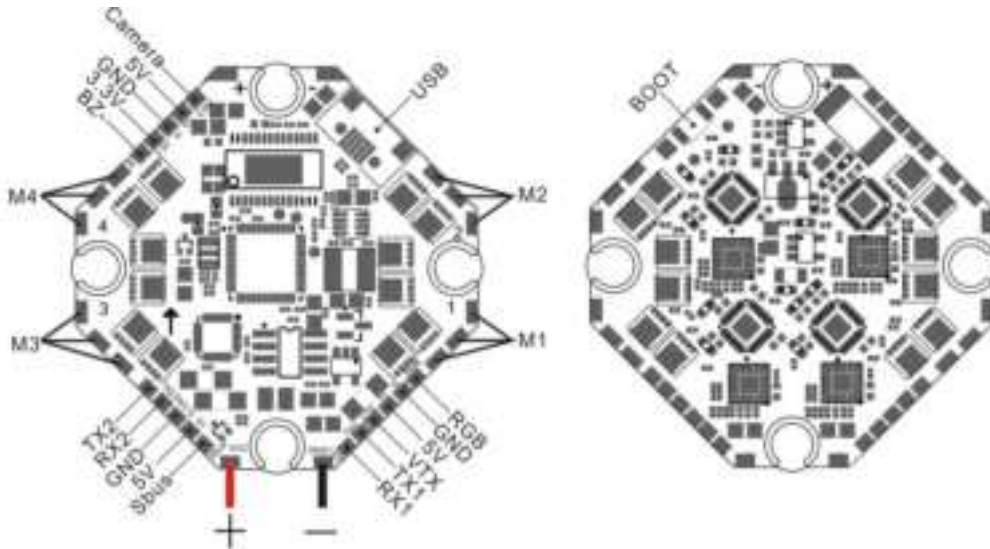

Babyhawk II HD's main electronic board is shown above. This board contains a F4 flight controller with all 4 esc's.

Emax Babyhawk II HD Flight Controller (FC)

This flight controller has a F4 MCU with a MPU6000 gyro. Babyhawk II HD flight controller comes pre-programmed and properly tuned for optimal flight. The flight controller is programmed with Betaflight 4.2.5. For a full tune and configuration setting file (CLI dump file) please visit <https://emax-usa.com/> for the CLI dump file.

Stock Flight Controller Settings

Babyhawk II HD is configured to take a channel map of the TAER1234 convention. That is the channel map is in the respective order: throttle, aileron, elevator, rudder, AUX 1, AUX 2, AUX 3, and AUX 4. The arm switch on Babyhawk II HD is set on AUX 1 and armed with the highest value. AUX 2 is configured for a 3 stage switch to select flight modes: Acro, Horizon, and Angle activating in an increasing order. AUX 3 is configured for the beeper. In a high state the motors will beep. AUX 4 is set to Flip Over After Crash mode (often referred to as turtle mode). Turtle mode is set when AUX 4 is in a high state. Please configure your radio as described above or change these settings in Betaflight Configurator.

Adjusting Software Settings (Betaflight Configurator)

Betaflight Configurator can be used to changed programmed settings on Babyhawk II HD and to flash new firmware if desired. Betaflight Configurator and flight controller firmware can be downloaded at <https://github.com/betaflight/>. The hardware target for Babyhawk II HD Flight Controller is STM32F411.

DISCLAIMER: We do not suggest changing any PID settings on Babyhawk II HD or upgrading the firmware to new versions. Babyhawk II HD comes stock with an optimal tune for superior flight performance. Changing this can affect flight time, overall speed, control of the aircraft, and excessive heat within the motors.

Reprogramming Babyhawk II HD Flight Controller

1. Put the Flight Controller in DFU mode by pressing the BOOT button while plugging in the micro USB cable to a computer.

2. Select STM32F411 as the target and then select the firmware (4.2.5) or download the hex file from <https://emax-usa.com/> . Select Manual Baud Rate with 256000 in the drop down menu
3. Select Load Firmware(Online) to download the firmware or Load Firmware (Local) if already downloaded the hex file.
4. Select Flash Firmware to program the flight controller



Set the Correct Settings

1. Download the latest CLI Dump File from <https://emax-usa.com/>
2. Connect Babyhawk II HD to Betaflight configurator and select the CLI tab
3. Open the CLI Dump File in a text editor and copy all the text.
4. Paste the settings into the command bar and press enter
5. Babyhawk II HD will reconnect to Betaflight when completed

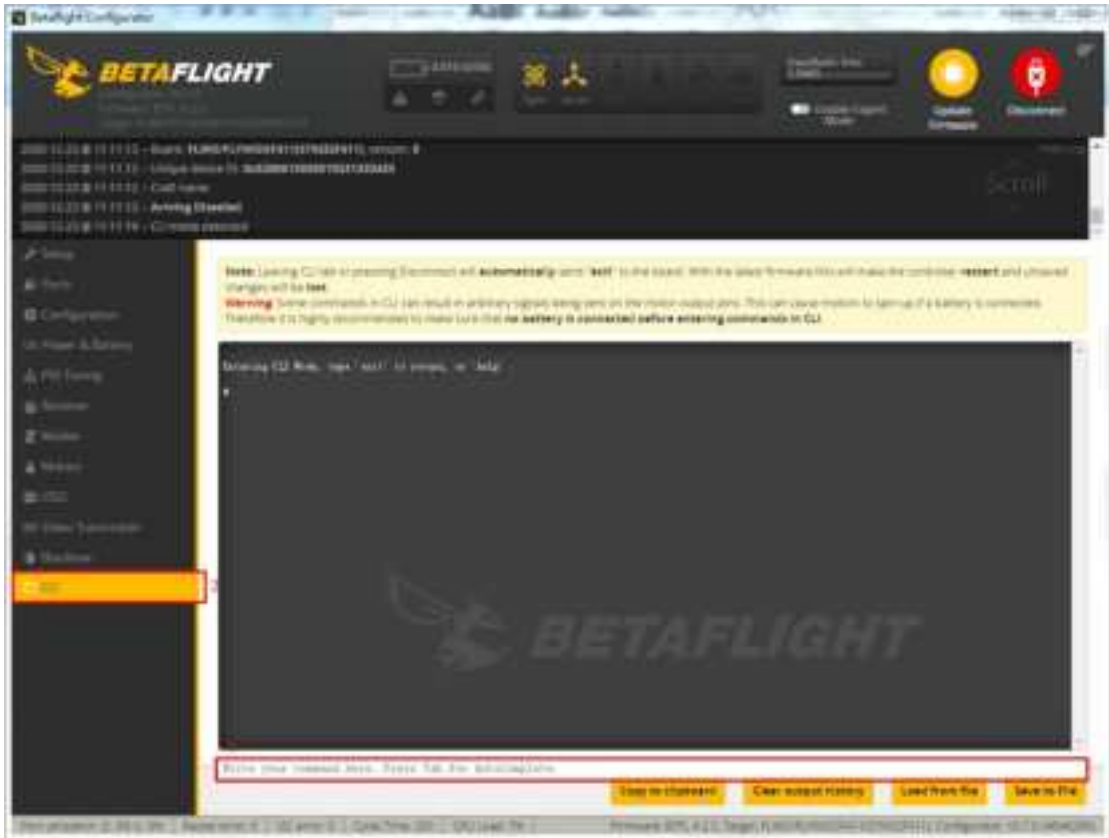

Flight

Always use caution when flying and operate in an open and controllable area. Please learn the flight controls first before powering on the aircraft to fly.

Radio Stick Controls

The left stick controls throttle and yaw direction of Babyhawk II HD. The right stick controls pitch and roll of the aircraft.

Left Stick Diagram

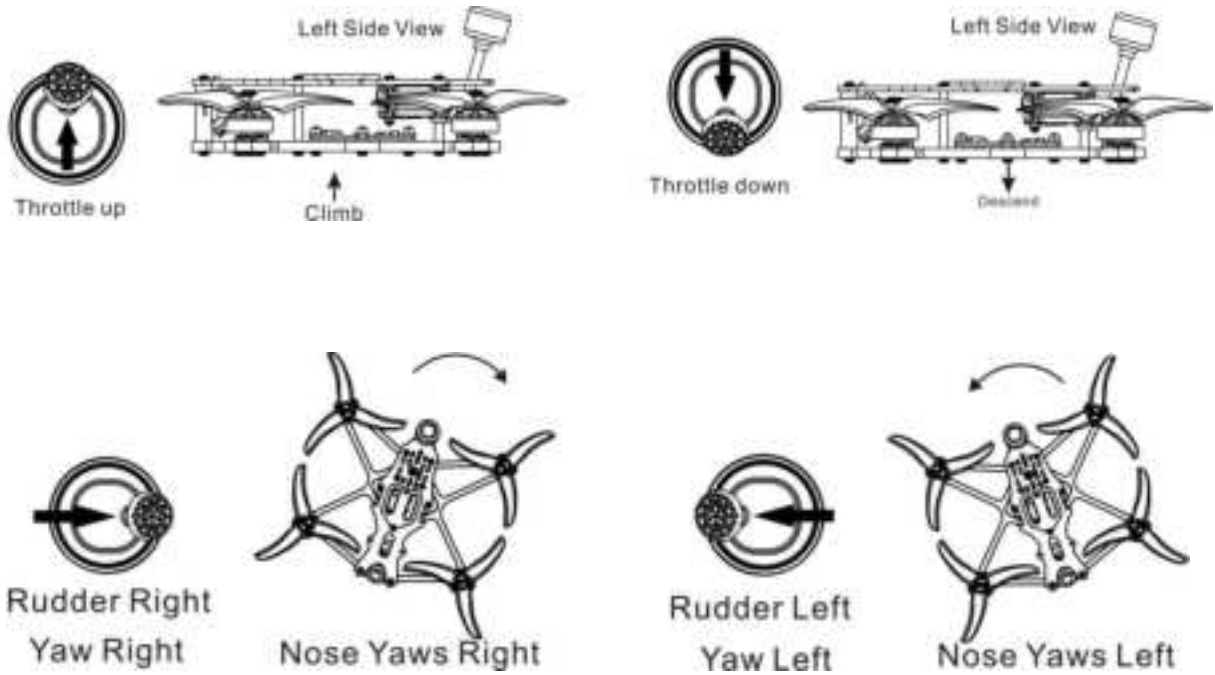

Right Stick Diagram

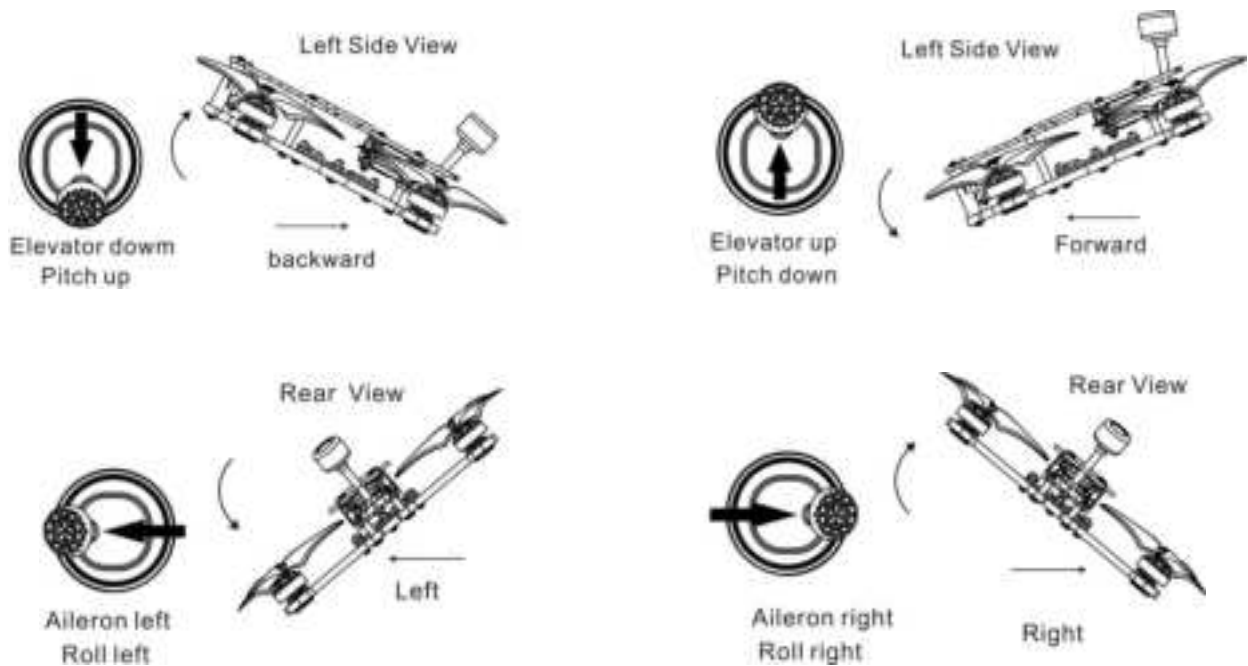

Fly Babyhawk II HD

Start by powering on your Radio and Goggles. Babyhawk II HD connected to 4S 850mah battery. Once the battery is plugged in, set Babyhawk II HD on a stable surface so it can calibrate. Calibration takes a few seconds then Babyhawk II HD is ready to fly. Babyhawk II HD can fly for 4 minutes on a fully charged battery. Land Babyhawk II HD when the battery reaches 14.4v; flying any longer can severely damage your battery and is not recommended.

Arming

Arming refers to setting Babyhawk II HD to a fly ready state. When Babyhawk II HD is powered on first it will not spin up the propellers until it is armed. Arm the aircraft by first moving throttle to the bottom position. Then move the AUX 1 switch of the radio to its 3rd position upwards. You will see the propellers spinning when Babyhawk II HD is successfully armed. In the event of a crash always disarm immediately. Failure to disarm in a timely manner can damage Babyhawk II HD.

Always disarm Babyhawk II HD before handling it.

1. Throttle down



2. Switch to Arm Position



Flying Modes

Babyhawk II HD comes stock set in rate mode. This is an advance mode where control sets the angular rate of the aircraft. The AUX 2 switch is set to change this mode on a 3 stage switch. When AUX 2 is in a high state, Babyhawk II HD will be in angle mode where control sets the attitude of the aircraft. When the switch is in the middle state, Babyhawk II HD will be in Horizon mode.

Line of Sight Flying

To learn how to fly Babyhawk II HD start by flying it line of sight (no goggles yet). Power on Babyhawk II HD and set it down in a cleared room. Arm Babyhawk II HD then throttle up using the left stick to a hover position. Work on maintaining a constant altitude. Pitch and roll Babyhawk II HD with the right thumb stick and yaw Babyhawk II HD with the left thumb stick.

First Person View (FPV) Flying

Make sure Babyhawk II HD and the goggles are on the same vtx channel and that you have a clear area to fly around in. Apply the same principals learned when flying Babyhawk II HD line of sight except now work on flying in a forward direction while maintaining a controlled constant altitude. It is easier to learn flying FPV by always moving in a forward direction so always apply a slight amount of pitch using your right thumb stick. You can steer Babyhawk II HD like a car using yaw on the left thumb stick.

There is an on screen display (OSD) overlaying the video feed from the camera of Babyhawk II HD. The OSD displays important information such as flight time and battery voltage. Pay attention to these numbers during flight to know how much battery life is left. Babyhawk II HD can fly for a maximum of 4 minutes. When the battery reaches 14.4v, land Babyhawk II HD. Dropping the battery below 14.4v is not suggested and can damage the battery.

Tips: Work on maintaining a controlled altitude flight to begin while driving Babyhawk II HD with pitch and yaw. Do not let the battery go lower than 14.4v. The AUX 3 switch activates a beeper when set in the 3rd position (high); this is useful when looking for Babyhawk II HD.

Thank you for purchasing our product! Enjoy Flying Babyhawk II HD.



Warning:

Please pay attention to your surroundings. Not
Recommended for persons under 18 years of age.